



# Operation **Manual**

## **Goodrive300-LIFT** Series Inverter



SHENZHEN INVT ELECTRIC CO., LTD.

## Preface

Goodrive300-LIFT (GD300L for short) series inverters for lifts are the new generation of lift-dedicated inverters, which use the GD control platform for development based on CHV180 series inverters. Applying advanced variable frequency vector control and modular interface design, the product improves the security reliability, control performance, and ease of commissioning and features the following:

- Compatible with asynchronous and synchronous motors.
- Starting torque compensation control with weighing sensors: implements slide prevention by setting parameters.
- Starting torque compensation control without weighing sensors: implements precise control on gearless synchronous-tractor lifts, which achieves stable startup.
- Static identification on initial pole angles of synchronous motors: For permanent magnet synchronous motors, autotuning can be executed when the motors are static. This simplifies the commissioning process and is applicable to commission the motors in mechanical connection.
- S-curve function: Acceleration (ACC) and deceleration (DEC) S curve algorithms improve the comfortability during motor ACC, DEC, and stop.
- Brake and contactor control function: controls contactors and braking based on lift running logic, enhancing lift security.
- ASR optimization: ASR uses variable proportional and integral gain control, providing dynamic response in startup and stop states and improving comfortability during constant-speed running.
- Forced DEC handling: prevents top-hitting and bottom-clashing during the upward or downward running of lifts.
- Emergency operation function: implements stop at convenient leveling for the equipment of UPS and storage battery input interfaces.
- Energy-saving operation: implemented for using the optional RBU series energy feedback unit.

# Contents

<b>Preface</b> .....	<b>i</b>
<b>Contents</b> .....	<b>ii</b>
<b>1 Safety precautions</b> .....	<b>1</b>
1.1 What this chapter contains .....	1
1.2 Safety definition .....	1
1.3 Warning signs .....	1
1.4 Safety guide .....	2
<b>2 Precautions for quick application</b> .....	<b>5</b>
2.1 What this chapter contains .....	5
2.2 Unpacking inspection .....	5
2.3 Application confirmation .....	5
2.4 Environment confirmation .....	5
2.5 Installation confirmation .....	6
2.6 Basic commissioning .....	7
<b>3 Product overview</b> .....	<b>8</b>
3.1 What this chapter contains .....	8
3.2 Basic principles .....	8
3.3 Product specifications .....	9
3.4 Name plate .....	11
3.5 Type designation key .....	11
3.6 Rated specifications .....	12
3.7 Structure diagram .....	12
<b>4 Installation guide</b> .....	<b>14</b>
4.1 What this chapter contains .....	14
4.2 Mechanical installation .....	14
4.3 Wiring .....	20
4.4 Wiring protection .....	26
<b>5 Keypad operation procedure</b> .....	<b>28</b>
5.1 What this chapter contains .....	28
5.2 Keypad .....	28
5.3 Keypad displaying .....	30
5.4 Keypad operation .....	31
<b>6 Function parameters</b> .....	<b>34</b>
6.1 What this chapter contains .....	34
6.2 Function parameters .....	34
<b>7 Commissioning guidelines</b> .....	<b>76</b>
7.1 What this chapter contains .....	76
7.2 Wiring between the lift controller and inverter .....	77
7.3 Setting basic parameters .....	77
7.4 Debugging running .....	79
7.5 Lift running mode .....	82
<b>8 Fault tracking</b> .....	<b>95</b>
8.1 What this chapter contains .....	95
8.2 Alarm and fault indications .....	95

8.3 How to reset.....	95
8.4 Fault history.....	95
8.5 Inverter faults and solutions.....	95
8.6 Common fault analysis.....	102
<b>9 Maintenance and hardware diagnosis .....</b>	<b>108</b>
9.1 What this chapter contains.....	108
9.2 Maintenance intervals .....	108
9.3 Cooling fan.....	110
9.4 Capacitors.....	111
9.5 Power cable.....	112
<b>10 Communication protocol.....</b>	<b>113</b>
10.1 What this chapter contains.....	113
10.2 Brief instruction to Modbus protocol.....	113
10.3 Application of the inverter .....	114
10.4 RTU command code and communication data illustration .....	119
10.5 Common communication faults.....	134
<b>Appendix A Expansion cards .....</b>	<b>135</b>
A.1 What this chapter contains.....	135
A.2 I/O expansion card.....	135
A.3 Asynchronous motor PG card .....	137
A.4 Synchronous motor PG card.....	140
A.5 STO instructions .....	143
<b>Appendix B Technical data.....</b>	<b>151</b>
B.1 What this chapter contains.....	151
B.2 Ratings.....	151
B.3 Grid specifications .....	152
B.4 Motor connection data .....	152
B.5 Applicable standards.....	153
B.6 EMC regulations .....	153
<b>Appendix C Dimension drawings.....</b>	<b>155</b>
C.1 What this chapter contains.....	155
C.2 Keypad structure .....	155
C.3 Inverter structure .....	156
C.4 Dimensions for inverters of AC 3PH 380V(-15%)–440V(+10%).....	156
<b>Appendix D Peripheral optional parts.....</b>	<b>158</b>
D.1 What this chapter contains.....	158
D.2 Peripheral wiring.....	158
D.3 Power supply.....	159
D.4 Cables.....	159
D.5 Breaker and electromagnetic contactor.....	162
D.6 Reactors.....	163
D.7 Filter.....	164
D.8 Braking system.....	166
D.9 Emergency operation systems.....	168
<b>Appendix E Further information.....</b>	<b>169</b>

# 1 Safety precautions

## 1.1 What this chapter contains

Read this manual carefully and follow all safety precautions before moving, installing, operating, and servicing the product. Otherwise, physical injury or death or damage to the devices may be caused.









For any physical injury or damage to the devices caused by you or your customers due to your neglect of the safety precautions, our company shall not be held liable.

## 1.2 Safety definition





Danger:	Serious physical injury or even death may be caused if related requirements are not followed.
Warning:	Physical injury or damage to the devices may be caused if related requirements are not followed.
Note:	Steps to take for ensuring the proper running of the product.
Qualified electricians:	People working on the device must have taken part in professional electrical and safety training, obtained the certification, and been familiar with all steps and requirements for installing, performing commissioning on, operating, and maintaining the device, and are capable of preventing or dealing with all kinds of emergencies.

## 1.3 Warning signs

Warning signs are used to warn you about the conditions that may cause severe injury or damage to the device. They instruct you to exercise caution to prevent danger. The following table describes the warning signs used in this manual.

Sign	Name	Description	Abbreviation
 Danger	Danger	Serious physical injury or even death may be caused if related requirements are not followed.	
 Warning	Warning	Physical injury or damage to the devices may be caused if related requirements are not followed.	
 Electrostatic discharge	Electrostatic discharge	Damage to the PCBA board may be caused if related requirements are not followed.	
 Hot sides	Hot sides	The base of the device may become hot. Do not touch it.	
<b>Note</b>	Note	Steps to take for ensuring the proper running of the device.	<b>Note</b>

### 1.4 Safety guide

	<ul style="list-style-type: none"> <li>◇ Only qualified electricians are allowed to operate the device.</li> <li>◇ Do not perform any wiring, inspection, or component replacement operations when power is applied. Before wiring or inspection, ensure that all input power supplies are disconnected and wait for at least the waiting time specified on the inverter, or ensure that the DC bus voltage is lower than 36 V. The following table describes the waiting time.</li> </ul> <table border="1" data-bbox="292 389 934 467" style="margin-left: auto; margin-right: auto;"> <thead> <tr> <th colspan="2" style="text-align: center;">Inverter model</th> <th style="text-align: center;">Minimum waiting time</th> </tr> </thead> <tbody> <tr> <td style="text-align: center;">380V</td> <td style="text-align: center;">4kW-30kW</td> <td style="text-align: center;">10 minutes</td> </tr> </tbody> </table>	Inverter model		Minimum waiting time	380V	4kW-30kW	10 minutes
Inverter model		Minimum waiting time					
380V	4kW-30kW	10 minutes					
	<ul style="list-style-type: none"> <li>◇ Do not refit the product unauthorzedly; otherwise fire, electric shocks or other injury may be caused.</li> </ul>						
	<ul style="list-style-type: none"> <li>◇ The base may become hot when the machine is running. Do not touch it. Otherwise, you may get burnt.</li> </ul>						
	<ul style="list-style-type: none"> <li>◇ The electronic parts and components inside the inverter are electrostatic sensitive parts. Take measurements to prevent electrostatic discharge when performing operations involving them.</li> </ul>						

#### 1.4.1 Delivery and installation

	<ul style="list-style-type: none"> <li>◇ Do not install the inverter on inflammables. Prevent it from coming into contact with or adhering to inflammables.</li> <li>◇ Connect the optional brake components (brake resistor, brake unit, or feedback unit) according to the wiring diagram.</li> <li>◇ Do not operate the inverter if it is damaged or lack of components.</li> <li>◇ Do not touch the inverter with wet objects or any of your body parts. Otherwise, electric shocks may be caused.</li> </ul>
---	---

**Note:**

- ◇ Use proper handling and installation tools to avoid damage to the device or physical injury. Installers must take mechanical protective measures, such as wearing anti-smashing shoes and work clothes, to protect personal safety.
- ◇ Ensure that no physical impact or vibration occurs on the inverter during its transport and installation.
- ◇ Do not carry the machine only by its front cover. Otherwise, the machine may fall down.
- ◇ Install the inverter in a place that will prevent children or other people from touching it.
- ◇ The inverter cannot meet the low- and medium-voltage protection requirements stipulated in IEC61800-5-1 if it is installed on a site where the altitude is higher than 2000 m.
- ◇ Operate the inverter in environments that meet the operation requirements (for details, see section 4.2.1 "Installation environment").

- ◇ Prevent screws, cables, and other conductive items from dropping into the inverter.
- ◇ The leakage current of the inverter may be larger than 3.5 mA during operation. Perform reliable grounding and ensure that the grounding resistance is lower than 10  $\Omega$ . The conductivity of the PE grounding conductor is the same as that of the phase conductor (with the same sectional area).
- ◇ R, S and T are the power input terminals, while U, V and W are the the terminals for output to the motor. Connect the input power cables and motor cables properly. Otherwise, damage to the inverter may be caused.

#### 1.4.2 Commissioning and operation

	<ul style="list-style-type: none"> <li>◇ Before wiring the terminals of the inverter, disconnect all power supplies applied to it and wait for at least the waiting time specified on it..</li> <li>◇ The voltage is high inside the inverter when it is running. Except settings through the keypad, do not perform any other operations on it.</li> <li>◇ The inverter cannot be used independently as an "emergency-stop device".</li> <li>◇ The product cannot be used for motor emergency braking. You need to configure a mechanical brake device.</li> <li>◇ When the inverter is used to drive a permanent-magnet synchronous motor (PMSM), ensure the following in addition to the preceding precautions:             <ol style="list-style-type: none"> <li>1. All the input power supplies, including the main power supply and control power supply, are disconnected.</li> <li>2. The running of the PMSM is stopped, and the voltage on the output side of the inverter is lower than 36 V.</li> <li>3. The waiting time after the PMSM is stopped is not shorter than the waiting time specified on the inverter, and the voltage between (+) and (-) is lower than 36 V.</li> <li>4. During the operation, ensure that the PMSM will not rotate again due to external loads. It is recommended that you configure an effective external brake device or disconnect the electrical connection between the PMSM and the inverter.</li> </ol> </li> </ul>
---	--

#### Note:

- ◇ Do not switch on or off the input power supply of the inverter frequently.
- ◇ If the inverter has been stored for a long time, check, set the capacity of, and perform a test run on it before using it. For details about inspection and capacity setting, see chapter 9. "Maintenance and hardware fault diagnosis".
- ◇ Close the front cover of the inverter before running it. Otherwise, electric shocks may be caused.



**1.4.3 Component maintenance and replacement**

	<ul style="list-style-type: none"> <li>◇ Only trained and qualified electricians are allowed to maintain, check, and replace components of the inverter.</li> <li>◇ Before wiring the terminals of the inverter, disconnect all power supplies applied to it and wait for at least the waiting time specified on it.</li> <li>◇ During the maintenance and replacement of components, take measures to prevent screws, cables, and other conductive items from dropping into the inverter.</li> </ul>
---	---

**Note:**

- ◇ Tighten the screws with proper torque.
- ◇ During the maintenance and replacement of components, prevent the inverter and its components from coming into contact with or being attached with inflammables.
- ◇ Do not perform any insulation or withstand voltage tests on the inverter. Do not use a megameter to measure the control circuit of the inverter.
- ◇ During the maintenance and replacement of components, take measurements to prevent electrostatic discharge for the inverter and its internal components.

**1.4.4 What to do after scrapping**

	<ul style="list-style-type: none"> <li>◇ There are heavy metals in the inverter. Deal with it as industrial effluent.</li> </ul>
	<ul style="list-style-type: none"> <li>◇ When the life cycle ends, the inverter should enter the recycling system. Dispose of it separately at an appropriate collection point instead of placing it in the normal waste stream.</li> </ul>

## 2 Precautions for quick application

### 2.1 What this chapter contains

This chapter describes the basic principles for the installation and commission of the inverter, which helps you to quickly complete the installation and commissioning.

### 2.2 Unpacking inspection

Check the following items after receiving the product.

1. Whether the packing box is damaged or dampened.
2. Whether the model identifier on the exterior surface of the packing box is consistent with the purchased model.
3. Whether the interior surface of the packing box is abnormal, for example, in wet condition, or whether the enclosure of the product is damaged or cracked.
4. Whether the nameplate of the product is consistent with the model identifier on the exterior surface of the packing box.
5. Whether the accessories (including the user manual, control keypad, and extension cards) inside the packing box are complete.

If any of the problems described in the check items are found, contact the local dealer or our company.

### 2.3 Application confirmation

Confirm the following items before using the inverter.

1. Mechanical type of the load to be driven by the inverter. Check whether the inverter will be overloaded in actual operation and whether the power level needs to be raised.
2. Whether the actual running current of the to-be-loaded motor is lower than the rated current of the inverter.
3. Whether control precision implemented by the inverter meets the requirement of the actual load.
4. Whether the grid voltage is consistent with the rated voltage of the inverter.
5. Whether you need to configure an extension card to implement the required communication mode.

### 2.4 Environment confirmation

Check the following items before you install and use the inverter.

1. Whether the ambient temperature in the application is higher than 40°C. If yes, derate the machine by 3% for every increased 1°C. Do not use the inverter in environments where the temperature is higher than 50°C. <b>Note:</b> If the inverter is installed in a cabinet, the ambient temperature is the air temperature
---

inside the cabinet.
2. Whether the ambient temperature in application is lower than $-10^{\circ}\text{C}$ . If yes, configure a heating device. <b>Note:</b> If the inverter is installed in a cabinet, the ambient temperature is the air temperature inside the cabinet.
3. Whether the altitude on the site is higher than 1000 m. If yes, derate the machine by 1% for every increased 100 m.
4. Whether the ambient humidity is higher than 90% or condensation occurs. If yes, take extra protective measures.
5. Whether there is direct sunlight or biological invasion in the application environment. If yes, take extra protective measures.
6. Whether there is dust or inflammable and explosive gas in the application environment. If yes, take extra protective measures.

## 2.5 Installation confirmation

Check the following items after the installation of the inverter is complete.

1. Whether the input power cables and motor cables meet the current-carrying capacity requirements of the actual load.
2. Whether the peripheral accessories are correctly selected and properly installed, and whether the installation cables meet the current-carrying capacity requirements of the accessories, including the input reactor, input filter, output reactor, output filter, DC reactor, brake unit, and brake resistor.
3. Whether the inverter is installed on non-flammable materials, and whether its heat-emitting accessories (such as reactor and brake resistor) are kept away from inflammable materials.
4. Whether all the control cables are wired separately from power cables, and whether electromagnetic compatibility (EMC) specification requirements are taken into full account during the wiring.
5. Whether all the grounding systems are properly grounded according to the requirements of the inverter.
6. Whether all the installation spacings of the inverter meet the requirements stated in the manual.
7. Whether the installation of the inverter meets the requirements stated in the manual.
8. Check that the external connection terminals are tightly fastened and whether the torque meets the requirements.
9. Whether screws, cables, or other conductive items drop into the inverter. If yes, take them out.

## 2.6 Basic commissioning

Complete the basic commissioning as follows before using the inverter.

1. Select the motor type and set the motor parameters according to the actual motor parameters, and set the control mode of the inverter.
2. Perform autotuning if required. Remove the motor load, if possible, to perform dynamic parameter autotuning; and if the load cannot be removed, you can perform static autotuning.
3. Adjust the ACC/DEC time according to the actual operation conditions of the load.
4. Perform commissioning on the machine in jogging mode and check whether the rotating direction of the motor meets the requirement. If no, exchange the wires of any two phases of the motor to change the running direction of the motor.
5. Set all control parameters and then run the machine.

### 3 Product overview

#### 3.1 What this chapter contains

The chapter briefly describes the operation principle, product characteristics, layout, name plate and type designation information.

#### 3.2 Basic principles

GD300L series inverters special for lifts are wall mountable devices for controlling asynchronous AC induction motors and permanent magnet synchronous motors.

The diagram below shows the simplified main circuit diagram of the inverter. The rectifier converts three-phase AC voltage to DC voltage. The capacitor bank of the intermediate circuit stabilizes the DC voltage. The converter transforms the DC voltage back to AC voltage for the AC motor. The brake pipe connects the external brake resistor to the intermediate DC circuit to consume the feedback energy when the voltage in the circuit exceeds its maximum limit.

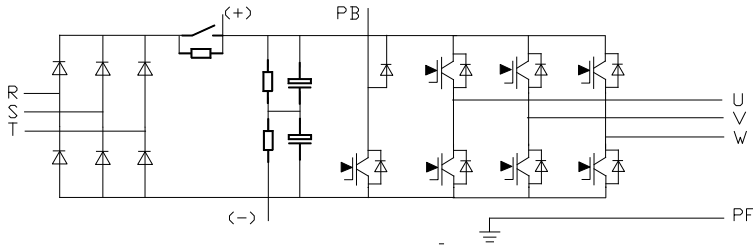

Figure 3-1 Main circuit for 4–5.5kW inverters

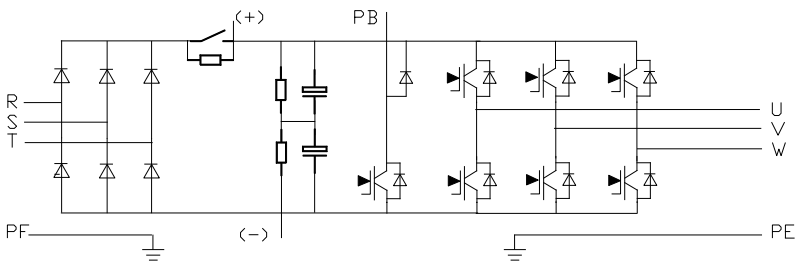

Figure 3-2 Main circuit for 7.5–15kW inverters

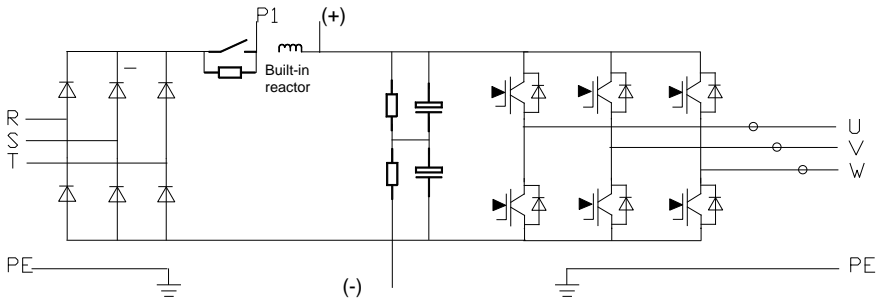

Figure 3-3 Main circuit for 18.5–30kW inverters

**Note:**

- The inverters  $\leq 15\text{kW}$  contain built-in brake units and supports external brake resistors which are optional.
- The 18.5–30kW inverters contain built-in DC reactors and support external brake units which are optional.

**3.3 Product specifications**

Function		Specifications
Power input	Input voltage (V)	Rated voltage: AC 380V (Available voltage degrees: 220, 380, 400, 415, 440, which can be set by the function code) Allowed input working voltage range: AC 1PH 220V(-15%)–240V(+10%) AC 3PH 380V(-15%)–440V(+10%)
	Input current (A)	Refer to the rated value.
	Input frequency (Hz)	50Hz or 60Hz Allowed range: 47–63Hz
Power output	Output voltage (V)	0–input voltage
	Output current (A)	Refer to 3.6 Rated specifications.
	Output power (kW)	Refer to 3.6 Rated specifications.
	Output frequency (Hz)	0–400Hz
Technical control feature	Control mode	SVPWM, sensorless vector control
	Motor type	Asynchronous motor and permanent magnet synchronous motor
	Adjustable-speed ratio	For open-loop vector control: 1:200 For closed-loop vector control: 1:1500
	Speed control accuracy	$\pm 0.5\%$ (open-loop vector); $\pm 0.05\%$ (closed-loop vector)

Function		Specifications
	Speed fluctuation	± 0.3%(sensorless vector control)
	Torque response	<20ms(sensorless vector control)
	Torque control accuracy	10% (sensorless vector control)
	Starting torque	For asynchronous motor sensorless vector control: 0.3Hz/150% For sensor-included vector control: 0 Hz/200%
	Overload capability	150% of rated current: 1 minute 180% of rated current: 10 seconds 200% of rated current: 1 second
Running control feature	Frequency setting method	Digital setting, analog setting, multi-step speed running setting, and MODBUS communication setting implement switching between channels.
	Voltage auto-adjustment	Keep constant voltage automatically when the grid voltage transients.
	Fault protection	Provide more than 30 fault protection functions against faults such as overcurrent, overvoltage, undervoltage, overheating, phase loss and overload.
Peripheral interface	Analog input	1 input (AI1): 0–10V/0–20mA Resolution: ≤20mV
	Analog output	1 output (AO1): 0–10V/0–20mA Resolution: ≤20mV
	Digital input	8 common inputs; Max. frequency: 1kHz; internal impedance: 3.3kΩ; 1 high speed input; Max. frequency: 50kHz Resolution: ≤2ms
	Digital output	1 terminal Y for open collector output
	Relay output	3 NO programmable relay outputs; RO1A NO, RO1C common terminal RO2A NO, RO2C common terminal RO3A NO, RO3C common terminal Contactor capability: 3A/AC250V, 1A/DC30V
	Power output	Provides 24V/200mA and 10V/50mA power output.
	PG expansion card (optional)	Incremental 5–24V; sine and cosine; absolute value; UVW

Function		Specifications
	IO expansion cards (optional)	3 common digital inputs 1 analog input AI2 1 NO/NC relay output 1 HDO output 1 Y output 1 RS485 interface (supporting RTU) 1 CAN communication interface
	STO expansion card (optional)	Provides STO security terminal functions.
	Bluetooth/Ethernet expansion card (optional)	Commissions devices through Bluetooth or Ethernet communication.
Others	Mountable method	Wall mounting
	Running environment temperature	-10–50°C. The inverter must be derated if temperature is above 40°C.
	MTBF	100,000 hours
	Protective degree	IP20
	Cooling	Forced air cooling
	Brake unit	Built in inverters ≤15kW; optional for others
	DC reactor	DC reactors are standard configuration for inverters ≥18.5kW.
EMC filter	Optional filters C2 can be configured, meeting IEC618000-3 C2 requirements.	

### 3.4 Name plate

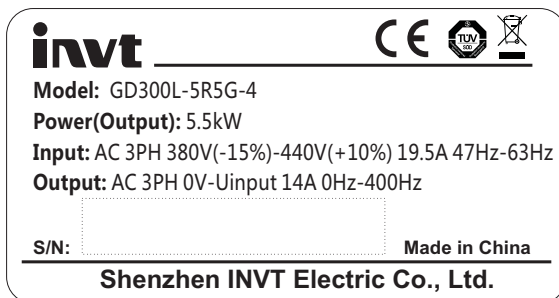

Figure 3-4 Name plate

**Note:** The certification mark such as "CE" can be placed only after the product is certified.

### 3.5 Type designation key

The type designation contains inverter information. You can find the type designation on the type designation label attached to the inverter or the simple name plate.



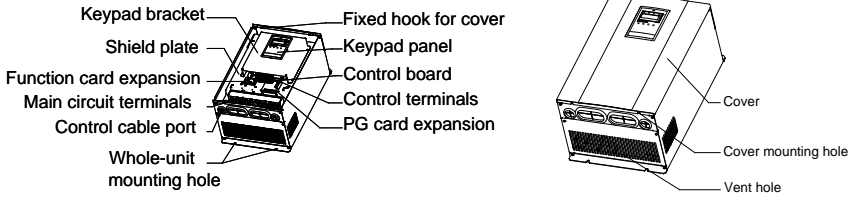



Figure 3-7 Components of inverters  $\geq 18.5$  kW

## 4 Installation guide

### 4.1 What this chapter contains

The chapter describes the mechanical installation and electric installation.

	<ul style="list-style-type: none"> <li>◇ Only qualified electricians are allowed to carry out what described in this chapter. Please operate as the instructions in <b>Safety precautions</b>. Ignoring these may cause physical injury or death or damage to the devices.</li> <li>◇ Ensure the power supply of the inverter is disconnected during the operation. Wait for at least the time designated until the CHARGE indicator is off after the disconnection if the power supply is applied. It is recommended to use the multimeter to monitor whether the drive DC bus voltage is under 36V.</li> <li>◇ The installation and design of the inverter should comply with the requirement of the local laws and regulations in the installation site. If the installation infringes the requirement, our company will exempt from any responsibility. Additionally, if users do not comply with the suggestion, some damage beyond the assured maintenance range may occur.</li> </ul>
---	--

### 4.2 Mechanical installation

#### 4.2.1 Installation environment

The installation environment is the safeguard for a full performance and long-term stable functions of the inverter. Check the installation environment as follows:

Environment	Conditions
Installation site	Indoor
Environment temperature	<p>-10—+50°C</p> <p>If the ambient temperature of the inverter is above 40°C, derate 3% for every additional 1°C.</p> <p>It is not recommended to use the inverter if the ambient temperature is above 50°C.</p> <p>In order to improve the reliability of the device, do not use the inverter if the ambient temperature changes frequently.</p> <p>Please provide cooling fan or air conditioner to control the internal ambient temperature below the required one if the inverter is used in a closed space such as in the control cabinet.</p> <p>When the temperature is too low, if the inverter needs to restart to run after a long stop, it is necessary to provide an external heating device to increase the internal temperature, otherwise damage to the devices</p>

Environment	Conditions
	may occur.
Humidity	RH≤90% No condensation is allowed. The maximum relative humidity should be equal to or less than 60% in corrosive air.
Storage temperature	-30—+60°C
Running environment	The inverter installation site should: <ul style="list-style-type: none"> <li>• keep away from the electromagnetic radiation source;</li> <li>• keep away from contaminative air, such as corrosive gas, oil mist and flammable gas;</li> <li>• ensure foreign objects, such as metal power, dust, oil, water cannot enter into the inverter (do not install the inverter on the flammable materials such as wood);</li> <li>• keep away from radioactive and flammable materials, direct sunlight, contaminative liquids, salty and vibration environments.</li> </ul>
Altitude	<1000m When the altitude exceeds 1000m but is lower than 3000m, derate 1% for every additional 100m; When the altitude exceeds 2000m, configure an isolation transformer on the input end of the inverter. When the altitude exceeds 3000m but is lower than 5000m, contact our company for technical consultation. Do not use the inverter at an altitude higher than 5000m.
Pollution level	Level 2
Vibration	≤ 5.8m/s <sup>2</sup> (0.6g)
Installation direction	The inverter needs to be installed on an upright position to ensure good cooling conditions.

**Note:**

- GD300L series inverters should be installed in a clean and ventilated environment according to enclosure classification.
- Cooling air must be clean, free from corrosive materials and electrically conductive dust.

**4.2.2 Installation direction**

The inverter may be installed on the wall or in a cabinet.

The inverter must be installed in an upright position. Check the installation direction according to the requirements below. Refer to Appendix C "Dimension drawings" for frame details.



## 4.2.5 Multiple-inverter installation

### Parallel installation

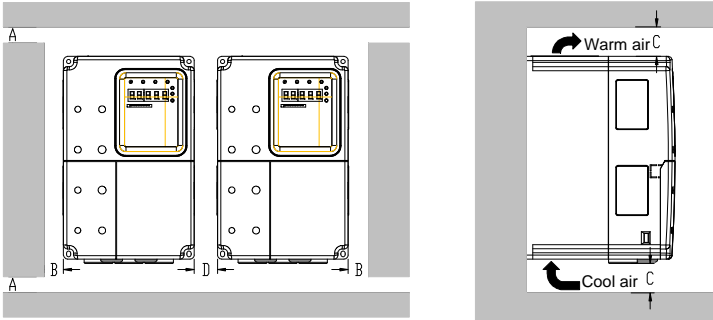

Figure 4-4 Parallel installation

**Note:**

- Before installing inverters in different sizes, align their top positions for the convenience of later maintenance.
- The minimum space of B, D and C is 100mm.

### 4.2.6 Vertical installation

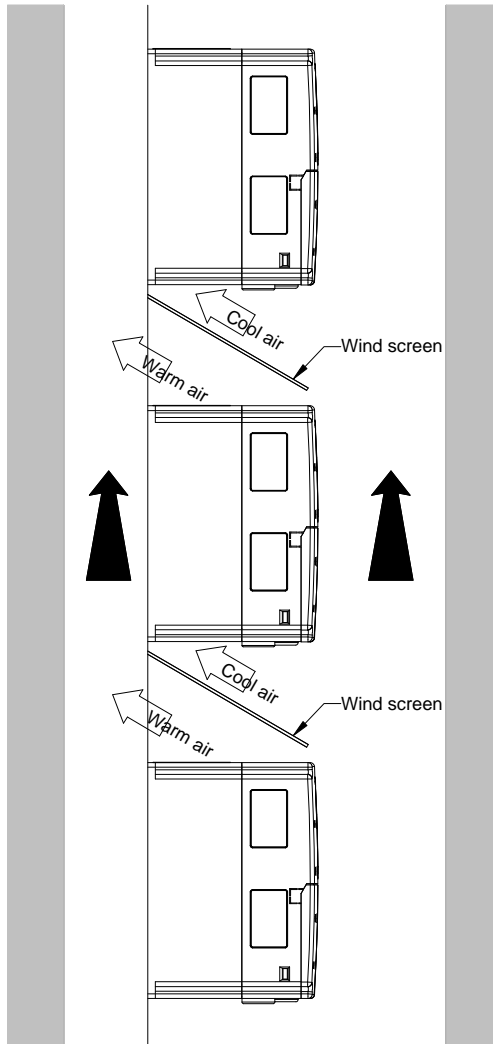

Figure 4-5 Vertical installation

**Note:** Windscreens are needed in vertical installation to avoid insufficient cooling due to mutual impact.

### 4.2.7 Tilt installation

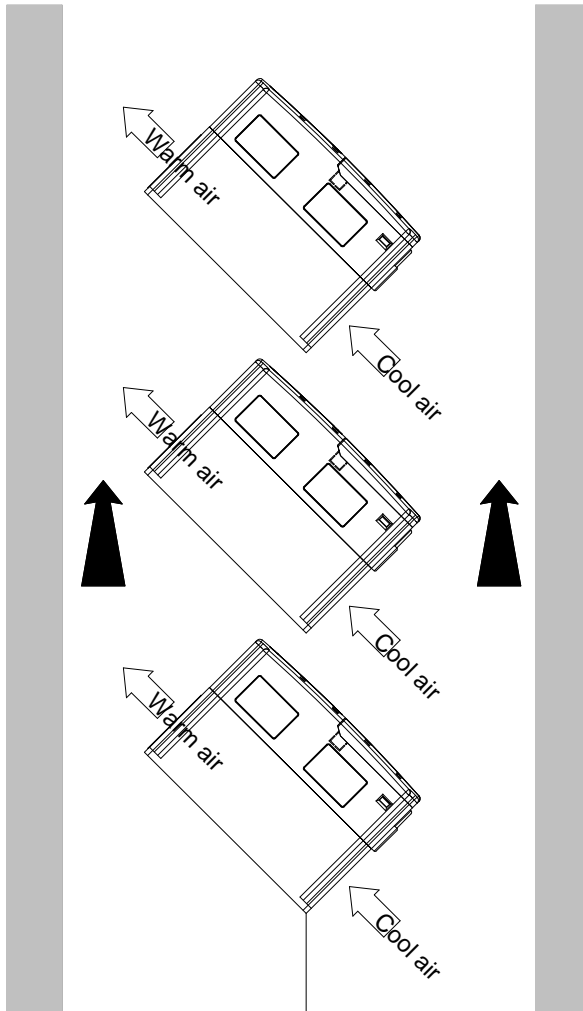

Figure 4-6 Tilt installation

**Note:** Ensure the separation of the wind input and output channels in tilt installation for avoiding mutual impact.

### 4.3 Wiring

#### 4.3.1 Connection to peripheral devices

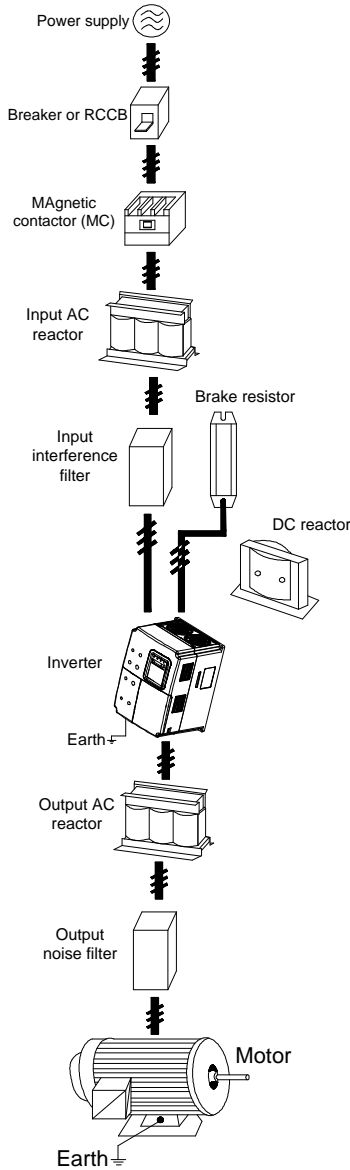

Figure 4-7 Connection to peripheral devices

### 4.3.2 Connection diagram of main circuit

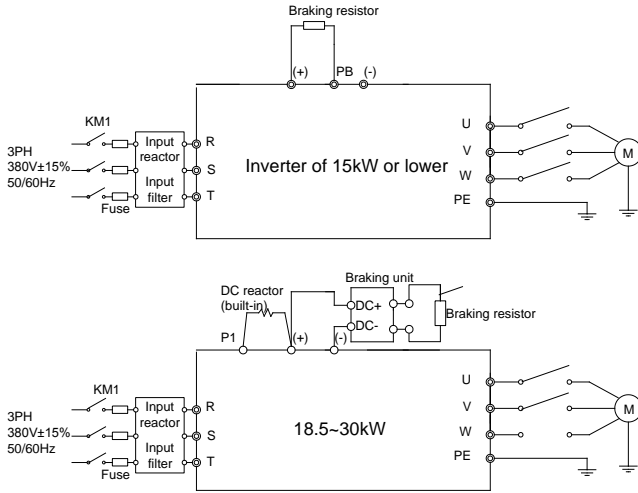

Figure 4-8 Connection diagram of main circuit for 380V inverters

**Note:**

- The fuse, DC reactor, brake unit, brake resistor, input reactor, input filter, output reactor, output filter are optional parts. Refer to **Peripheral optional parts** for detailed information.
- The inverters of 18.5–30kW contain built-in DC reactors.

### 4.3.3 Terminals in main circuit

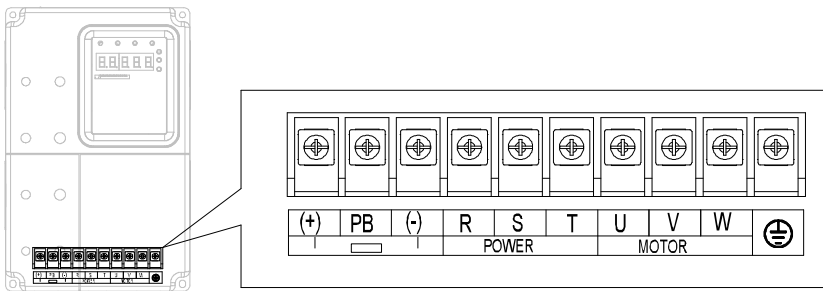

Figure 4-9 Terminals of main circuit for the inverters of 380V 4–5.5kW

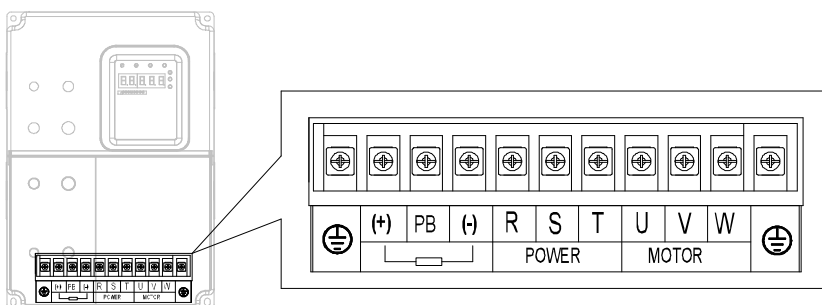

Figure 4-10 Terminals of main circuit for the inverters of 380V 7.5–15 kW

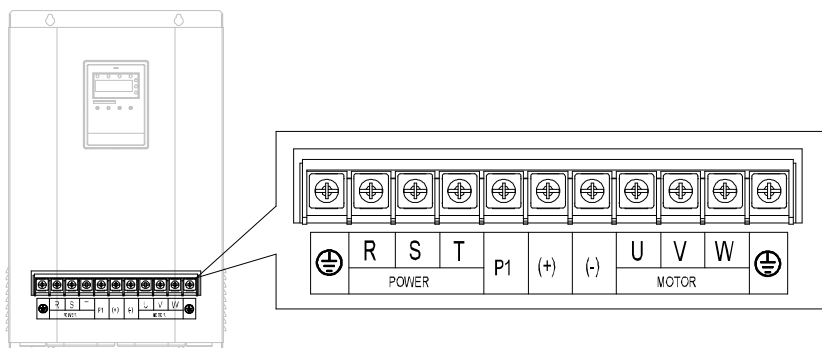

Figure 4-11 Terminals of main circuit for the inverters of 380V 18.5–30kW

Terminal	Name	Function
R, S, T	Power input of main circuit	3PH AC input terminals, connected to the grid
(+), (-)	Reserved terminal for connecting external brake units	Reserved terminal for connecting external brake units
(+), PB	Reserved terminals for connecting external brake resistors	Reserved terminals for connecting external brake resistors
P1, (+)	Reserved terminals for connecting external DC reactors	Reserved terminals for connecting external DC reactors
(-)	DC negative bus output terminal	DC negative bus output terminal
U, V, W	Inverter output	3PH AC output terminals, generally connected to the motor
⊕	Grounding terminal	Grounding terminal

**Note:**

- Do not use an asymmetrically constructed motor cable. If there is a symmetrically constructed

grounding conductor in the motor cable in addition to the conductive shield, connect the grounding conductor to the grounding terminal at the inverter and motor ends.

- Brake resistor, brake unit, and DC reactor are optional parts.
- Route the motor cable, input power cable, and control cables separately.

#### 4.3.4 Wiring of terminals in main circuit

1. Connect the ground wire of the input power cable to the ground terminal (PE) of the inverter, and connect the 3PH input cable to the terminals R, S, and T, and fasten them up.
2. Connect the ground wire of the motor cable to the ground terminal of the inverter, and connect the 3PH motor cable to the terminals U, V, and W, and fasten them up.
3. Connect the brake resistor and other accessories that are equipped with cables to the specified positions.
4. Fasten all the cables outside of the inverter mechanically, if possible.

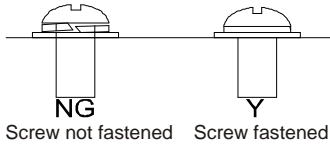

Figure 4-12 Proper screw fastening

4.3.5 Connection diagram of control circuit

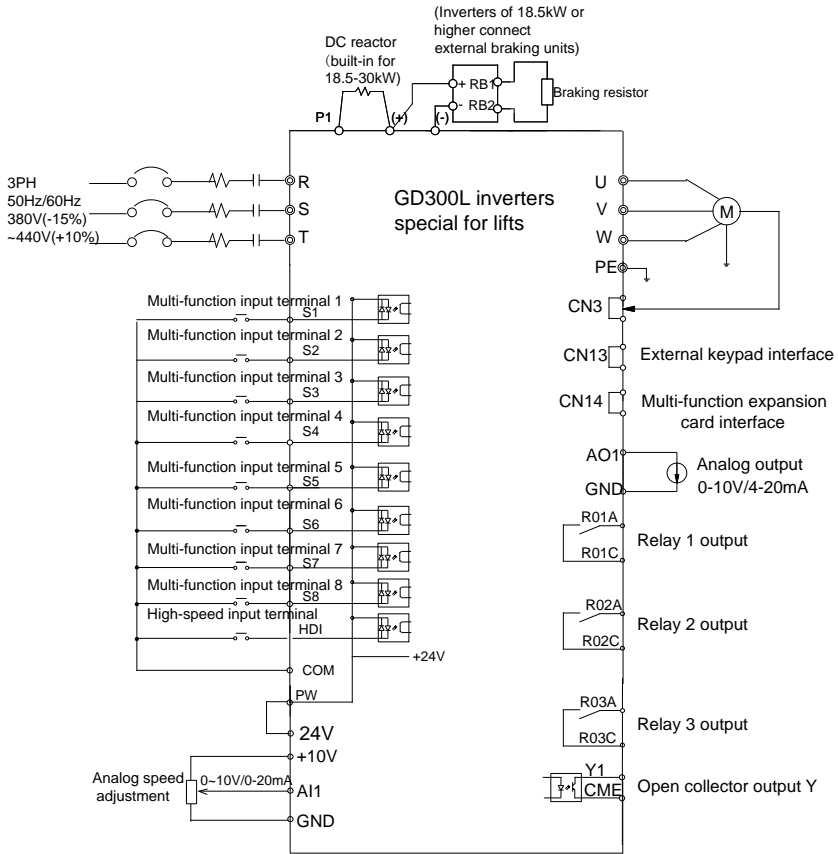

Figure 4-13 Connection diagram of control circuit

4.3.6 Terminals in control circuit

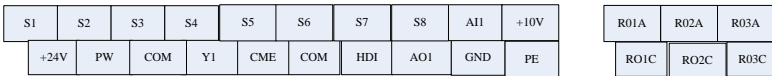

Figure 4-14 Terminals in control circuit

Terminal	Description
S1-S7	Common digital input terminals 1. Internal impedance: 3.3kΩ 2. 12–30V voltage input acceptable 3. Dual-direction input terminals, supporting both NPN and PNP 4. Max input frequency: 1kHz

Terminal	Description
	5. All are programmable digital input terminals. Terminal functions can be set by function codes.
HDI	1. It can serve as the high-frequency pulse input channel, besides the functions of S1–S8. 2. Max. input frequency: 50kHz
COM	Common terminal of +24V
PW	To provide the input digital power supply from external to internal. Voltage range: 12–24V
+10V	+10V power provided by the local device
AI1	1. Input range: 0–10V/0–20mA for AI1 voltage/current, switched by J3 2. Input impedance: 20k $\Omega$ for voltage input; 500 $\Omega$ for current input 4. Resolution: 5mV as the min. resolution when 10V corresponds to 50Hz. 5. Deviation $\pm 1\%$ , 25 $^{\circ}$ C
GND	Reference zero potential of +10V
AO1	1. Input range: 0–10V/0–20mA for AO1 voltage/current, switched by J1 2. Deviation $\pm 1\%$ , 25 $^{\circ}$ C
Y1	1. Switch capacity: 200mA/30V 2. Output frequency range: 0–1kHz
CME	Common terminal of open connector output
RO1A	RO1 relay output, RO1A NO, RO1C common terminal
RO1C	Contact capacity: 3A/AC250V, 1A/DC30V
RO2A	RO2 relay output, RO2A NO, RO2C common terminal
RO2C	Contact capacity: 3A/AC250V, 1A/DC30V
RO3A	RO3 relay output, RO3A NO, RO3C common terminal
RO3C	Contact capacity: 3A/AC250V, 1A/DC30V

#### 4.3.7 Input/Output signal connection

Use the U-shaped contact tag to set the NPN mode or PNP mode and the internal or external power supply. The default setting is NPN internal mode.

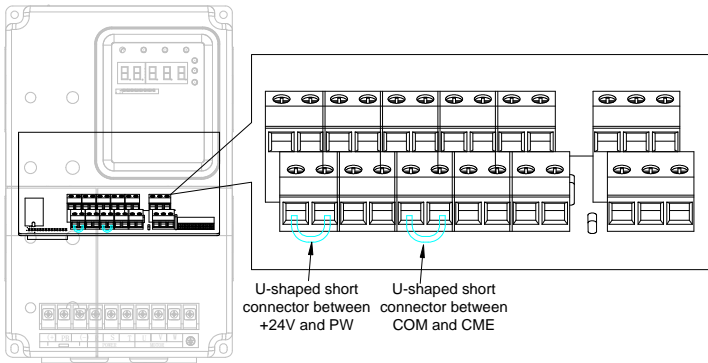
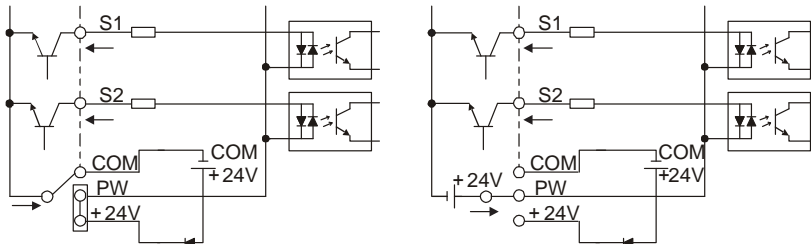

Figure 4-15 U-shaped contact tag

If the signal is from NPN transistor, please set the U-shaped contact tag between +24V and PW as below according to the used power supply.



Internal power supply (NPN mode)

External power supply (NPN mode)

Figure 4-16 NPN modes

If the signal is from PNP transistor, please set the U-shaped contact tag as below according to the used power supply.

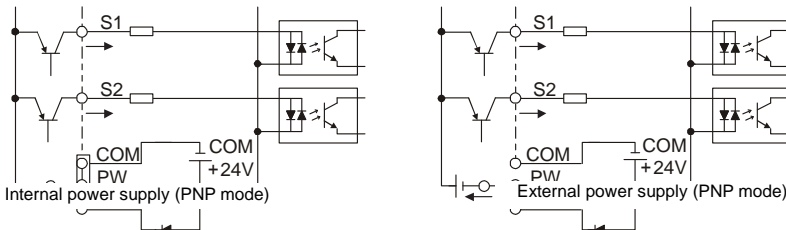

Internal power supply (PNP mode)

External power supply (PNP mode)

Figure 4-17 PNP modes

## 4.4 Wiring protection

### 4.4.1 Protecting the inverter and input power cable in short-circuit situations

Protect the inverter and input power cable against thermal overload in short circuit situations. Arrange the protection according to the following guidelines.

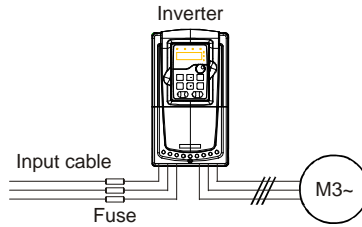

Figure 4-18 Fuse configuration

**Note:** Select the fuse as the manual indicated. The fuse will protect the input power cable from damage in short-circuit situations. It will protect the surrounding devices when the internal of the inverter is short circuited.

#### 4.4.2 Protecting the motor and motor cable in short-circuit situations

The inverter protects the motor and motor cable in a short-circuit situation when the motor cable is dimensioned according to the rated current of the inverter. No additional protection devices are needed.



⇨ If the inverter is connected to multiple motors, a separate thermal overload switch or a circuit breaker must be used for protecting each cable and motor. These devices may require a separate fuse to cut off the short-circuit current.

#### 4.4.3 Protecting the motor against thermal overload

According to regulations, the motor must be protected against thermal overload and the current must be switched off when overload is detected. The inverter includes a motor thermal protection function that protects the motor and closes the output to switch off the current when necessary.

## 5 Keypad operation procedure

### 5.1 What this chapter contains

This chapter describes:

Buttons, indicating lights and the screen as well as the methods to inspect, modify and set function codes by keypad

### 5.2 Keypad

The keypad is used to control GD300L series inverters special for lifts, read the state data, and adjust parameters.









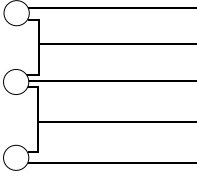

Figure 5-1 Keypad

**Note:** The LED keypad is provided as standard configuration. There is another optional LCD keypad which supports various languages, parameter copy, and 10-line displaying, and is compatible with the LED keypad in installation dimensions.

No.	Name	Description	
1	State LED	RUN/TUNE	LED off means that the inverter is in the stopping state; LED blinking means the inverter is in the parameter autotune state; LED on means the inverter is in the running state.
		FWD/REV	FED/REV LED LED off means the inverter is in the forward rotation state; LED on means the inverter is in the reverse rotation state
		LOCAL/REMOT	LED for keypad operation, terminals operation and remote communication control

No.	Name	Description					
			LED off means that the inverter is in the keypad operation state; LED blinking means the inverter is in the terminals operation state; LED on means the inverter is in the remote communication control state.				
		<b>TRIP</b>	LED for faults LED on when the inverter is in the fault state; LED off in normal state; LED blinking means the inverter is in the alarm state.				
2	Unit LED	Mean the unit displayed currently					
			Hz	Frequency unit			
			RPM	Rotating speed unit			
			A	Current unit			
			%	Percentage			
		V	Voltage unit				
3	Code displaying zone	5-digit LED display displays various monitoring data and alarm code such as set frequency and output frequency.					
		Displayed character	Corresponding character	Displayed character	Corresponding character	Displayed character	Corresponding character
		0	0	1	1	2	2
		3	3	4	4	5	5
			6	7	7	8	8
		9	9	A	A	b	b
		C	C	d	d	E	E
		F	F	H	H	I	I
		L	L	N	N	n	n
		O	O	P	P	r	r
S	S	t	t	U	U		
v	v	.	.	-	-		
4	Digital potentium	Reserved					

No.	Name	Description		
	eter			
5	Buttons		Programming key	Enter or escape from the first level menu and remove the parameter quickly.
			Entry key	Enter the menu step-by-step. Confirm parameters.
			UP key	Increase data or function code progressively.
			DOWN key	Decrease data or function code progressively.
			Right-shift key	Move right to select the displaying parameter circularly in stopping and running mode. Select the parameter modifying digit during the parameter modification.
			Run key	This key is used to operate on the inverter in key operation mode.
			Stop/ Reset key	This key is used to stop in running state and it is limited by function code <a href="#">P07.05</a> . This key is used to reset all control modes in the fault alarm state.
			Quick key	The function of this key is confirmed by function code <a href="#">P07.04</a> .



### 5.3 Keypad displaying

The keypad displaying state of Goodrive300L series inverters is divided into stopping state parameter, running state parameter, function code parameter editing state and fault alarm state and so on.

#### 5.3.1 Displayed state of stopping parameters

When the inverter is in the stopping state, the keypad will display stopping parameters as shown in Figure 5-2.

In the stopping state, various kinds of parameters can be displayed. Select the parameters to be displayed or not by [P07.08](#). See the instructions of [P07.08](#) for the detailed definition of each bit.

In the stopping state, there are 9 stopping parameters can be selected to be displayed or not. They are: set speed, set frequency, bus voltage, input terminals state, output terminals state, AI1, AI2, and magnetic pole position. [P07.08](#) determines whether to display the parameters by bit.  /SHIFT can shift the parameters form left to right, while  ([P07.04](#)=2) can shift the parameters form

right to left.

### 5.3.2 Displayed state of running parameters

After receiving valid running commands, the inverter will enter the running state and the keypad will display the running parameters. **RUN/TUNE** LED on the keypad is on, while the **FWD/REV** is determined by the current running direction, as shown in Figure 5-2.

In the running state, there are 16 parameters that can be displayed. They are: running speed, set speed, bus voltage, output voltage, output current, running frequency (Hz on), running rotation speed, output power, output torque, input terminals state, output terminals state, AI1, AI2, torque compensation, magnetic pole position, and linear speed. [P07.06](#) determines whether to display the parameters by bit. **➤/SHIFT** can shift the parameters from left to right, while **QUICK/JOG** ([P07.04](#)=2) can shift the parameters from right to left.

### 5.3.3 Displayed state of fault

If the inverter detects the fault signal, it will enter the fault alarm displaying state. The keypad will display the fault code by blinking. The **TRIP** LED on the keypad is on, and the fault reset can be operated by **STOP/RST** on the keypad, control terminals or communication commands.

### 5.3.4 Displayed state of function codes editing

In the state of stopping, running or fault, press **PRG/ESC** to enter into the editing state (if there is a password, see [P07.00](#)).The editing state is displayed on two classes of menu, and the order is: function code group/function code number→function code parameter, press **DATA/ENT** into the displayed state of function parameter. On this state, you can press **DATA/ENT** to save the parameters or press **PRG/ESC** to exit.

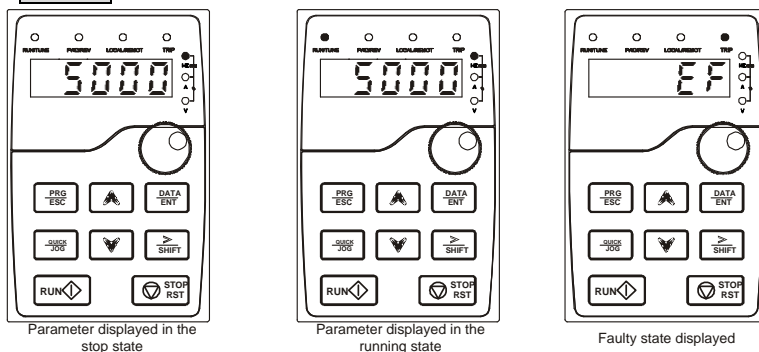

Figure 5-2 Displayed state

## 5.4 Keypad operation

Operate the inverter via operation panel. See the detailed structure description of function codes in the brief diagram of function codes.

### 5.4.1 How to modify the function codes of the inverter

The inverter has three levels menu, which are:

1. Group number of function code (first-level menu)
2. Tab of function code (second-level menu)
3. Set value of function code (third-level menu)

Remarks: Press both **PRG/ESC** or **DATA/ENT** to return to the second-level menu from the third-level menu. The difference is: pressing **DATA/ENT** will save the set parameters into the control panel, and then return to the second-level menu with shifting to the next function code automatically; while pressing **PRG/ESC** will directly return to the second-level menu without saving the parameters, and keep staying at the current function code.

Under the third-level menu, if the parameter has no blinking bit, it means the function code cannot be modified. The possible reasons could be:

- 1) This function code is not modifiable parameter, such as actual detected parameter, operation records and so on;
- 2) This function code is not modifiable in running state, but modifiable in stop state.

Example: Set function code **P00.01** from 0 to 1.

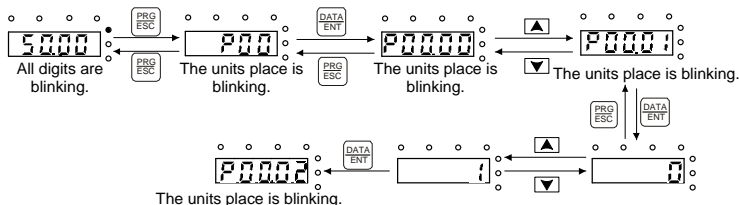

**Note:** When setting the value, you can press **PRG/ESC** and **▲+▼** to modify the value.

Figure 5-3 Sketch map of modifying parameters

### 5.4.2 How to set the password of the inverter

Goodrive300L series inverters special for lifts provide password protection function to users. Set **P07.00** to gain the password and the password protection becomes valid instantly after quitting from the function code editing state. Press **PRG/ESC** again to the function code editing state, "0.0.0.0.0" will be displayed. Unless using the correct password, you cannot enter it.

Set **P07.00** to 0 to cancel password protection function.

The password protection becomes effective 1 minute later after retreating from the function code editing state. Press **PRG/ESC** again to the function code editing state, "0.0.0.0.0" will be displayed. Unless using the correct password, you cannot enter it.

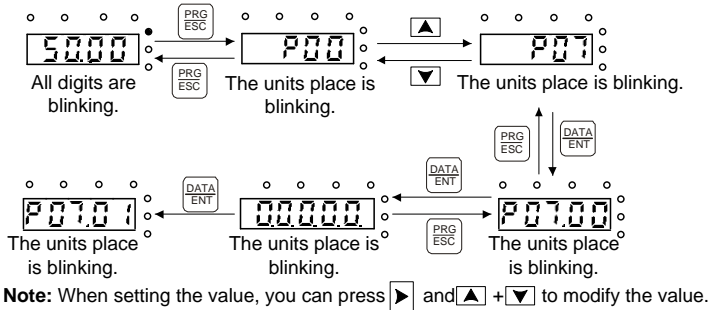

Figure 5-4 Sketch map of password setting

### 5.4.3 How to watch the inverter state through function codes

Goodrive300L series inverters special for lifts provide group [P17](#) as the state inspection group. You can enter [P17](#) directly to view the state.

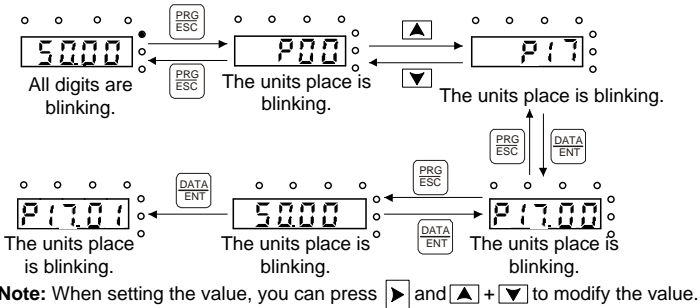

Figure 5-5 Sketch map of state viewing

## 6 Function parameters

### 6.1 What this chapter contains

This chapter lists and describes the function parameters.

### 6.2 Function parameters

The function parameters of GD300L series inverters special for lifts are divided into 30 groups (P00–P29) by function, of which P18–P19 and P22–P28 are reserved. Each function group contains certain function codes applying 3-level menus. For example, "[P08.08](#)" means the eighth function code in the P8 group function. P29 group is factory reserved and inaccessible for users.

For the convenience of function codes setting, the function group number corresponds to the first level menu, the function code corresponds to the second level menu and the function code corresponds to the third level menu.

1. Below is the instruction of the function lists:

**The first line** "Function code": codes of function parameter group and parameters;

**The second line** "Name": full name of function parameters;

**The third line** "Detailed illustration of parameters": detailed illustration of the function parameters

**The fourth line** "Default value": the original factory values of the function parameter;

**The fifth line** "Modify": the modifying character of function codes (the parameters can be modified or not and the modifying conditions), below is the instruction:

"○": means the set value of the parameter can be modified on stop and running state;

"◎": means the set value of the parameter cannot be modified on the running state;

"●": means the value of the parameter is the real detection value which cannot be modified.

(The inverter has limited the automatic inspection of the modifying character of the parameters to help users avoid misadjustment.)

2. "Parameter radix" is decimal (DEC), if the parameter is expressed by hex, then the parameter is separated from each other when editing. The setting range of certain bits are 0–F (Hex).

3. "The default value" means the function parameter will restore to the default value during default parameters restoring, but the detected parameter or recorded value is not restored.

4. For a better parameter protection, the inverter provides password protection to the parameters. After setting the password (set [P07.00](#) to any non-zero number), the system will come into the state of password verification firstly after the user press **PRG/ESC** to come into the function code editing state. And then "0.0.0.0.0." will be displayed. Unless the user input right password, they cannot enter into the system. For the factory setting parameter zone, it needs correct factory password (remind that the users cannot modify the factory parameters by themselves, otherwise, if the parameter setting is incorrect, damage to the inverter may occur). If the password protection is unlocked, the user can modify the password freely and the inverter will work as the last setting one. When [P07.00](#) is set to 0,

the password can be canceled. If [P07.00](#) is not 0 during powering on, then the parameter is protected by the password. When modify parameters by serial communication, the password function also follows the above rules.

Function code	Name	Detailed instruction of parameters	Default value	Modify
<b>P00 Group Basic function group</b>				
P00.00	Speed control mode	0: Sensorless vector control (SVC) mode 0 1: SVC mode 1 2: V/F control 3: Closed-loop vector control	2	⊙
P00.01	Run command channel	0: Keypad ("LOCAL/REMOT" off) 1: Terminal ("LOCAL/REMOT" blinking) 2: Communication ("LOCAL/REMOT" on) 3: CAN ("LOCAL/REMOT" on)	1	⊙
P00.02	Lift rated speed	0.100–4.000m/s	1.500m/s	⊙
P00.03	Speed command selection	0: Keypad 1: AI1 2: AI2 3: Multi-step speed running 4: Remote communication 5: AI1 tracking running 6: CAN communication-based setting 7: CAN communication-based reference	3	⊙
P00.04	Max. output frequency	10.00–600.00Hz	50.00 Hz	⊙
P00.05	Keypad set speed	0– <a href="#">P00.02</a> (lift rated speed)	1.500m/s	○
P00.06	Running direction	0: Default direction 1: Reverse direction 2: Forbid to run in reverse direction	0	⊙
P00.07	Carrier frequency mode	0: Fixed carrier frequency, set by <a href="#">P00.08</a> 1: Auto adjustment	0	⊙

Function code	Name	Detailed instruction of parameters	Default value	Modify											
P00.08	Carrier frequency setting	<table border="1"> <thead> <tr> <th>Carrier frequency</th> <th>Electromagnetic noise</th> <th>Noise and leakage current</th> <th>Heat dissipation</th> </tr> </thead> <tbody> <tr> <td>1 kHz</td> <td rowspan="3">↑ High ↓ Low</td> <td rowspan="3">↑ Low ↓ High</td> <td rowspan="3">↑ Low ↓ High</td> </tr> <tr> <td>10 kHz</td> </tr> <tr> <td>15 kHz</td> </tr> </tbody> </table>	Carrier frequency	Electromagnetic noise	Noise and leakage current	Heat dissipation	1 kHz	↑ High ↓ Low	↑ Low ↓ High	↑ Low ↓ High	10 kHz	15 kHz	Depend on model	©	
		Carrier frequency	Electromagnetic noise	Noise and leakage current	Heat dissipation										
1 kHz	↑ High ↓ Low	↑ Low ↓ High	↑ Low ↓ High												
10 kHz															
15 kHz															
<p>Mapping between models and carrier frequencies</p> <table border="1"> <thead> <tr> <th colspan="2">Model</th> <th>Default carrier frequency</th> </tr> </thead> <tbody> <tr> <td rowspan="3">380V</td> <td>1.5–11kW</td> <td>8 kHz</td> </tr> <tr> <td>15–55kW</td> <td>4 kHz</td> </tr> <tr> <td>&gt;75kW</td> <td>2 kHz</td> </tr> <tr> <td rowspan="2">660V</td> <td>22–55kW</td> <td>4 kHz</td> </tr> <tr> <td>&gt;75kW</td> <td>2 kHz</td> </tr> </tbody> </table> <p>Advantage of high carrier frequency: ideal current waveform, little current harmonic wave and motor noise.</p> <p>Disadvantage of high carrier frequency: increasing switch loss, increasing inverter temperature, and impact to output capacity. The inverter needs to derate on high carrier frequency. Besides, the leakage and electrical magnetic interference increases. Applying low carrier frequency is contrary to the above. Too low carrier frequency will cause unstable running, torque decreasing and surge.</p> <p>A reasonable carrier frequency has been set in factory. In general, you do not need to modify the parameter. When the frequency used exceeds the default one, the inverter needs to derate 20% for each additional 1kHz carrier frequency. Setting range: 1.2–15.0kHz</p>	Model		Default carrier frequency	380V	1.5–11kW	8 kHz	15–55kW	4 kHz	>75kW	2 kHz	660V	22–55kW	4 kHz	>75kW	2 kHz
Model		Default carrier frequency													
380V	1.5–11kW	8 kHz													
	15–55kW	4 kHz													
	>75kW	2 kHz													
660V	22–55kW	4 kHz													
	>75kW	2 kHz													

Function code	Name	Detailed instruction of parameters	Default value	Modify
P00.09	Motor parameter autotuning	0: No operation 1: Rotating parameter autotuning on empty-load asynchronous motor 2: Static parameter autotuning on asynchronous motor 3: Rotating parameter autotuning on empty-load synchronous motor 4: Static parameter autotuning on synchronous motor 5: Rotating parameter autotuning on synchronous motor with load	0	☉
P00.10	Function restore parameter	0: No operation 1: Restore the default value 2: Delete the fault records 3: Roll back function parameters, reading function parameters that are saved when the LSB of P07.01 is set to 5.	0	☉
P00.11	AVR function	0: Invalid 1: Valid	1	☉
P00.12	Reserved	0-65535	0	○
P00.13	Reserved	0-65535	0	○
<b>P01 Group Startup and stop control</b>				
P01.00	Start mode	0: Start-up directly: start from the starting frequency <a href="#">P01.01</a> 1: Start-up after DC braking: start the motor from the starting frequency after DC braking (setting <a href="#">P01.04</a> and <a href="#">P01.05</a> ) It is suitable in the cases where reverse rotation may occur to the low inertia load during starting.	0	☉
P01.01	Starting frequency of direct start	Starting frequency of direct start-up means the original frequency during the inverter starting. See <a href="#">P01.03</a> for detailed information. Setting range: 0.00–50.00Hz	0.00Hz	☉
P01.02	ACC time of start	0.000–0.100s	0.010s	☉

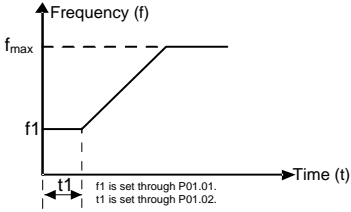
Function code	Name	Detailed instruction of parameters	Default value	Modify
P01.03	Retention time of the starting frequency	 <p>Set a proper starting frequency to increase the torque of the inverter during starting. During the retention time of the starting frequency, the output frequency of the inverter is the starting frequency. And then, the inverter will run from the starting frequency to the set frequency. If the set frequency is lower than the starting frequency, the inverter will stop running and keep in the stand-by state. The starting frequency is not limited in the lower limit frequency. Setting range: 0.0–50.0s</p>	0.0s	⊙
P01.04	Pre-start braking current	The inverter will carry out DC braking at the braking current set before starting and it will speed up after the DC braking time. If the DC braking time is set to 0, the DC braking is invalid.	0.0%	⊙
P01.05	Braking time before starting	Stronger braking current indicates bigger braking power. The DC braking current before starting means the percentage of the rated current of the inverter. Setting range of <a href="#">P01.04</a> : 0.0–100.0% Setting range of <a href="#">P01.05</a> : 0.0–30.0s	0.0s	⊙

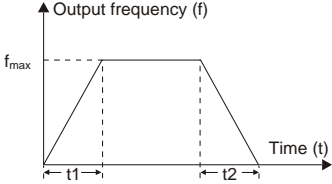
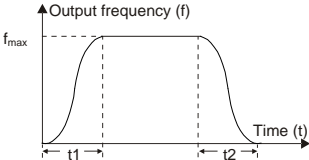
Function code	Name	Detailed instruction of parameters	Default value	Modify
P01.06	ACC/DEC selection	<p>Changing mode of the frequency during start-up and running.</p> <p>0: Linear type</p> <p>The output frequency increases or decreases linearly.</p>  <p>1: S curve, indicating the output frequency increases or decreases according to the S curve.</p> <p>Generally, S curve is used in scenarios such as lifts and conveyers which require smooth startup and stop.</p> 	0	☉
P01.07	Stop mode	<p>0: Decelerate to stop. After the stop command becomes valid, the inverter decelerates to decrease the output frequency during the set time. When the frequency decreases to <a href="#">P01.15</a>, the inverter stops.</p> <p>1: Coast to stop: after the stop command becomes valid, the inverter ceases the output immediately. And the load coasts to stop at the mechanical inertia.</p>	0	○
P01.08	Start frequency in stop braking	Starting frequency of stop braking: The inverter will carry on stop DC braking when the frequency is arrived during decelerating to stop.	0.00Hz	○
P01.09	Demagnetizing time		0.00s	○
P01.10	Stop DC braking current		Demagnetizing time: Before the stop DC	0.0%

Function code	Name	Detailed instruction of parameters	Default value	Modify
P01.11	DC braking time	<p>braking, the inverter will close output and begin to carry on the DC braking after the waiting time. This function avoids the overcurrent fault caused by DC braking when the speed is too high. Stop DC braking current: DC brake added. Stronger current indicates bigger DC braking effect.</p> <p>Braking time of stop braking: Retention time of DC brake. If the time is 0, the DC brake is invalid. The inverter will stop at the set deceleration time.</p> <p>Setting range of <a href="#">P01.08</a>: 0.00Hz–<a href="#">P00.04</a> (max. output frequency)                      Setting range of <a href="#">P01.09</a>: 0.00–30.00s                      Setting range of <a href="#">P01.10</a>: 0.0–100.0%                      Setting range of <a href="#">P01.11</a>: 0.0–50.0s</p>	0.0s	<input type="radio"/>
P01.12	Stop knee-point frequency	<p>0.00–10.00Hz                      In the process of deceleration to stop, the stop deceleration curve starts after the frequency set in this parameter is reached.</p>	1.00Hz	<input type="radio"/>
P01.13	Startup delay	<p>The function determines the brake release after the running command is given, and the inverter is in a stand-by state and waits for the delay time set by <a href="#">P01.13</a>.                      Setting range: 0.00–60.00s</p>	0.04s	<input type="radio"/>
P01.14	Reserved	0–65535	0	<input type="radio"/>
P01.15	Reserved	0–65535	0	<input type="radio"/>

Function code	Name	Detailed instruction of parameters	Default value	Modify
<b>P02 Group Motor 1</b>				
P02.00	Motor type	0: Asynchronous motor 1: Synchronous motor	0	☉
P02.01	Motor rated power	0.1–3000.0kW	Depend on model	☉
P02.02	Motor rated frequency	0.01Hz– <a href="#">P00.04</a> (max. frequency)	50.00Hz	☉
P02.03	Motor rated rotation speed	1–36000rpm	Depend on model	☉
P02.04	Motor rated voltage	0–1200V	Depend on model	☉
P02.05	Motor rated current	0.8–6000.0A	Depend on model	☉
P02.06	Stator resistor of asynchronous motor	0.001–65.535Ω	Depend on model	☉
P02.07	Rotor resistor of asynchronous motor	0.001–65.535Ω	Depend on model	☉
P02.08	Leakage inductance of asynchronous motor	0.1–6553.5mH	Depend on model	☉
P02.09	Mutual inductance of asynchronous motor	0.1–6553.5mH	Depend on model	☉
P02.10	Non-load current of asynchronous motor	0.1–6553.5A	Depend on model	☉
P02.11	Direct axis inductance of synchronous motor	0.01–655.35mH	Depend on model	☉
P02.12	Quadrature axis inductance of synchronous motor	0.01–655.35mH	Depend on model	☉
P02.13	Back EMF of synchronous motor	0–10000	300	☉

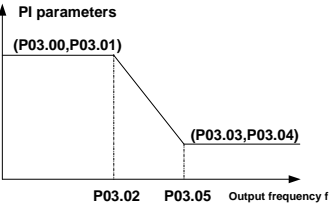
Function code	Name	Detailed instruction of parameters	Default value	Modify
P02.14	Pulley diameter	100–2000mm	500mm	☉
P02.15	DEC ratio	0.01–10.00	1.00	☉
P02.16	Speed regulation ratio	0–65535	1000	○
P02.17	Reserved	0–65535	0	○
<b>P03 Group Vector control</b>				
P03.00	Speed loop proportional gain 1	<p>The parameters <a href="#">P03.00–P03.05</a> only apply to vector control mode. Below the switching frequency 1 (<a href="#">P03.02</a>), the speed loop PI parameters are: <a href="#">P03.00</a> and <a href="#">P03.01</a>. Above the switching frequency 2 (<a href="#">P03.05</a>), the speed loop PI parameters are: <a href="#">P03.03</a> and <a href="#">P03.04</a>. PI parameters are gained according to the linear change of two groups of parameters. It is shown as below:</p>  <p>Setting the proportional coefficient and integral time of the adjustor can change the dynamic response performance of vector control speed loop. Increasing the proportional gain and decreasing the integral time can speed up the dynamic response of the speed loop. But too high proportional gain and too low integral time may cause system vibration and overshoot. Too low proportional gain may cause system</p>	16.0	○
P03.01	Speed loop integral time 1	vibration and speed static deviation.	0.200s	○
P03.02	Low switching frequency	PI has a close relationship with the inertia of the system. Adjust on the base of PI according to	5.00Hz	○

Function code	Name	Detailed instruction of parameters	Default value	Modify
P03.03	Speed loop proportional gain 2	different loads to meet various demands. Setting range of <a href="#">P03.00</a> : 0.0–200.0 Setting range of <a href="#">P03.01</a> : 0.000–10.000s Setting range of <a href="#">P03.02</a> : 0.00Hz–P03.05	10.0	<input type="radio"/>
P03.04	Speed loop integral time 2	Setting range of <a href="#">P03.03</a> : 0.0–200.0 Setting range of <a href="#">P03.04</a> : 0.000–10.000s Setting range of <a href="#">P03.05</a> : <a href="#">P03.02</a> – <a href="#">P00.04</a> (max. output frequency)	0.200s	<input type="radio"/>
P03.05	High switching frequency		10.00Hz	<input type="radio"/>
P03.06	Speed loop output filter	0–8 (corresponds to $0-2^8 \times 125 \mu\text{s}$ )	0	<input type="radio"/>
P03.07	Compensation coefficient of electromotion slip	Slip compensation coefficient is used to adjust the slip frequency of the vector control and improve the speed control accuracy of the system. Adjusting the parameter properly can control the speed steady-state error. Setting range: 50%–200%	100%	<input type="radio"/>
P03.08	Compensation coefficient of braking slip		100%	<input type="radio"/>
P03.09	Current loop percentage coefficient P	<b>Note:</b> 1. These two parameters adjust the PI adjustment parameter of the current loop which affects the dynamic response speed and control accuracy directly. Generally, keep the default values. 2. Only applicable to the vector control mode 0 without PG ( <a href="#">P00.00</a> =0). Setting range: 0–20000	1000	<input type="radio"/>
P03.10	Current loop integral coefficient I		1000	<input type="radio"/>
P03.11	Torque upper limit	0.0–200.0% (motor rated current)	180.0%	<input type="radio"/>
P03.12	Emergency operation torque upper limit	0.0–200.0% (motor rated current)	150.0%	<input checked="" type="radio"/>
P03.13	Reserved	0–65535	0	<input type="radio"/>
P03.14	Reserved	0–65535	0	<input type="radio"/>
<b>P04 Group V/F control</b>				
P04.00	Motor torque boost	Torque boost to the output voltage for the	0.0%	<input type="radio"/>

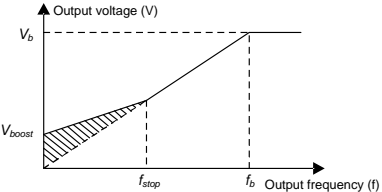
Function code	Name	Detailed instruction of parameters	Default value	Modify
P04.01	Torque boost close	<p>features of low frequency torque. <a href="#">P04.00</a> is for the max. output voltage <math>V_b</math>.</p> <p><a href="#">P04.01</a> defines the percentage of closing frequency of manual torque to <math>f_b</math>.</p> <p>Torque boost should be selected according to the load. The bigger the load is, the bigger the boost is. Too big torque boost is inappropriate because the motor will run with over-magnetic, and the current of the inverter will increase to raise the temperature of the inverter and decrease the efficiency.</p> <p>When the torque boost is set to 0.0%, the inverter is automatic torque boost.</p> <p>Torque boost threshold: under the threshold, the torque boost is valid, but over the threshold, the torque boost is invalid.</p>  <p>Setting range of <a href="#">P04.00</a>: 0.0% (default), 0.1%–10.0%</p> <p>Setting range of <a href="#">P04.01</a>: 0.0%–50.0%</p>	20.0%	○
P04.02	Motor V/F slip compensation gain	<p>This function code is used to compensate the change of the rotation speed caused by load during compensation SVPWM control to improve the rigidity of the motor. It can be set to the rated slip frequency of the motor which is counted as below:</p> $\Delta f = f_b - n \cdot p / 60$ <p>Of which, <math>f_b</math> is the rated frequency of the motor, its function code is <a href="#">P02.02</a>; <math>n</math> is the rated rotating</p>	100.0%	○

Function code	Name	Detailed instruction of parameters	Default value	Modify
		speed of the motor and its function code is <a href="#">P02.03</a> ; p is the pole pair of the motor. 100.0% corresponds to the rated slip frequency $\Delta$ f. Setting range: 0.0–200.0%		
P04.03	Motor vibration control factor at low frequency	0–100	10	<input type="radio"/>
P04.04	Motor vibration control factor at high frequency	0–100	10	<input type="radio"/>
P04.05	Motor vibration control threshold	In SVPWM control mode, current fluctuation may occur to the motor at some frequency, especially the motor with big power. The motor cannot run stably or overcurrent may occur. These phenomena can be canceled by adjusting this parameter. Setting range of <a href="#">P04.03</a> : 0–100 Setting range of <a href="#">P04.04</a> : 0–100 Setting range of <a href="#">P04.05</a> : 0.00Hz– <a href="#">P00.04</a> (max. output frequency)	30.00 Hz	<input type="radio"/>
P04.06	Energy-saving operation	0: No operation 1: Automatic energy-saving operation (reserved)	0	<input checked="" type="radio"/>
P04.07	Gain in SM MTPA control	0~3000	50	<input type="radio"/>
P04.08	Integral in SM MTPA control	0~3000	30	<input type="radio"/>
<b>P05 Group Input terminals</b>				
P05.00	HDI input selection	0: High-speed pulse input. See <a href="#">P05.27–P05.31</a> . 1: Digital input. See <a href="#">P05.12</a> .	0	<input checked="" type="radio"/>
P05.01	S1 function selection	0: No function 1: Running up (FWD) 2: Running down (REV)	1	<input checked="" type="radio"/>
P05.02	S2 function selection	3: Running in inspection mode (EXM) 4: Emergency running (EMER) 5: Coast to stop (FSTP)	2	<input checked="" type="radio"/>

Function code	Name	Detailed instruction of parameters	Default value	Modify																														
P05.03	S3 function selection	6: Fault reset (RET) 7: External fault (EF) 8: Multi-speed running terminal 1 (MS1)	8	⊙																														
P05.04	S4 function selection	9: Multi-speed running terminal 2 (MS2) 10: Multi-speed running terminal 3 (MS3) 11: Up forced deceleration 1 (UFS1) 12: Up forced deceleration 2 (UFS2)	9	⊙																														
P05.05	S5 function selection	13: Up forced deceleration 3 (UFS3) 14: Down forced deceleration 1 (DFS1) 15: Down forced deceleration 2 (DFS2)	3	⊙																														
P05.06	S6 function selection	16: Down forced deceleration 3 (DFS3) 17: Contactor feedback signal (TB) 18: Brake feedback signal (FB) 19: Enable inverter (ENA)	4	⊙																														
P05.07	S7 function selection	20: Forced decelerate to stop 21: Emergency mode 22: Motor overheat	0	⊙																														
P05.08	S8 function selection	23: Main power supply input disconnected (for India) 24: UPS input disconnected by main control (for India)	0	⊙																														
P05.09	S9 function selection	25: Base lockout 26–40: Reserved		⊙																														
P05.10	S10 function selection			⊙																														
P05.11	S11 function selection			⊙																														
P05.12	HDI function selection		0	⊙																														
P05.13	Polarity selection of input terminals	<p>The function code is used to set the polarity of input terminals.</p> <p>Set the bit to 0, the input terminal is positive.</p> <p>Set the bit to 1, the input terminal is negative.</p> <table border="1" style="width: 100%; border-collapse: collapse; text-align: center;"> <tr> <td></td><td></td><td></td><td>BIT11</td><td>BIT10</td></tr> <tr> <td></td><td></td><td></td><td>HDI</td><td>S11</td></tr> <tr> <td>BIT9</td><td>BIT8</td><td>BIT7</td><td>BIT6</td><td>BIT5</td></tr> <tr> <td>S10</td><td>S9</td><td>S8</td><td>S7</td><td>S6</td></tr> <tr> <td>BIT4</td><td>BIT3</td><td>BIT2</td><td>BIT1</td><td>BIT0</td></tr> <tr> <td>S5</td><td>S4</td><td>S3</td><td>S2</td><td>S1</td></tr> </table> <p>Setting range: 0x000–0x7FF</p>				BIT11	BIT10				HDI	S11	BIT9	BIT8	BIT7	BIT6	BIT5	S10	S9	S8	S7	S6	BIT4	BIT3	BIT2	BIT1	BIT0	S5	S4	S3	S2	S1	0x000	○
			BIT11	BIT10																														
			HDI	S11																														
BIT9	BIT8	BIT7	BIT6	BIT5																														
S10	S9	S8	S7	S6																														
BIT4	BIT3	BIT2	BIT1	BIT0																														
S5	S4	S3	S2	S1																														
P05.14	Digital filter time	Set the sample filter time of S1–S11 and HDI terminals. If the interference is strong, increase the parameter to avoid the disoperation. 0.000–1.000s	0.010s	○																														

Function code	Name	Detailed instruction of parameters	Default value	Modify
P05.15	Reserved	Reserved	0	⊙
P05.16	Enable power-on terminal detection	0: Disable 1: Enable (terminal command power-on response and terminal command response to UV fault rectification)	0	⊙
P05.17	Lower limit of AI1	The function code defines the relationship between the analog input voltage and its corresponding set value. If the analog input voltage beyond the set minimum or maximum input value, the inverter will count at the minimum or maximum one.  When the analog input is the current input, the corresponding voltage of 0–20mA is 0–10V. In different cases, the corresponding rated value of 100.0% is different. See the application for detailed information.  The figure below illustrates different applications:	0.00V	○
P05.18	Corresponding setting of the lower limit of AI1		0.0%	○
P05.19	Upper limit of AI1		10.00V	○
P05.20	Corresponding setting of the upper limit of AI1		100.0%	○
P05.21	AI1 input filter time		0.030s	○
P05.22	Lower limit of AI2		0.00V	○
P05.23	Corresponding setting of the lower limit of AI2		0.0%	○
P05.24	Upper limit of AI2		10.00V	○
P05.25	Corresponding setting of the upper limit of AI2	100.0%	○	
P05.26	AI2 input filter time	Input filter time: This parameter is used to adjust the sensitivity of the analog input. Increasing the value properly can enhance the anti-interference of the analog, but weaken the sensitivity of the analog input.  Note: Analog AI1 and AI2 can support 0–10V or 0–20mA input, when AI1 and AI2 selects 0–20mA input, the corresponding voltage of 20mA is 5V. AI3 can support the input of	0.030s	○

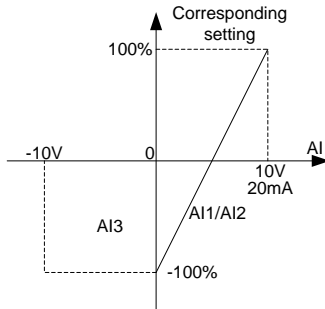

Function code	Name	Detailed instruction of parameters	Default value	Modify
		-10V→+10V. Setting range of <a href="#">P05.17</a> : 0.00V– <a href="#">P05.19</a> Setting range of <a href="#">P05.18</a> : -300.0%–300.0% Setting range of <a href="#">P05.19</a> : <a href="#">P05.17</a> –10.00V Setting range of <a href="#">P05.20</a> : -300.0%–300.0% Setting range of <a href="#">P05.21</a> : 0.000s–10.000s Setting range of <a href="#">P05.22</a> : 0.00V– <a href="#">P05.24</a> Setting range of <a href="#">P05.23</a> : -300.0%–300.0% Setting range of <a href="#">P05.24</a> : <a href="#">P05.22</a> –10.00V Setting range of <a href="#">P05.25</a> : -300.0%–300.0% Setting range of <a href="#">P05.26</a> : 0.000s–10.000s		
P05.27	Lower limit frequency of HDI	0.000 KHz – <a href="#">P05.29</a>	0.000K Hz	○
P05.28	Corresponding setting of HDI lower limit frequency	-300.0%–300.0%	0.0%	○
P05.29	Upper limit frequency of HDI	<a href="#">P05.27</a> –50.000kHz	50.000K Hz	○
P05.30	Corresponding setting of HDI upper limit frequency	-300.0%–300.0%	100.0%	○
P05.31	HDI frequency input filter time	0.000s–10.000s	0.030s	○
P05.32	Analog signal voltage threshold for motor thermal protection	0.0 V–10.0 V	0.0 V	○
P05.33	Reserved	0–65535	0	○
<b>P06 Group Output terminals</b>				
P06.00	HDO output	Function selection of the high-speed pulse output terminals. 0: Open collector pole high speed pulse output. The max.pulse frequency is 50.0kHz. See <a href="#">P06.16–P06.20</a> . 1: Open collector pole output. See <a href="#">P06.03</a> .	0	◎
P06.01	Y1 output	0: No output 1: Lift in operation	1	○
P06.02	Y2 output	2: Up operation	0	○

Function code	Name	Detailed instruction of parameters	Default value	Modify																
P06.03	HDO output	3: Down operation	0	<input type="radio"/>																
P06.04	Relay output RO1	4: Fault output	4	<input type="radio"/>																
P06.05	Relay output RO2	5: Zero speed running	7	<input type="radio"/>																
P06.06	Relay output RO3	6: Ready for running	8	<input type="radio"/>																
P06.07	Relay RO4 output	7: Braking control	0	<input type="radio"/>																
		8: Contactor control																		
		9: Frequency arrival																		
		10: Frequency detection threshold (FDT) output																		
		11: FDT reverse output																		
		12: Reserved																		
		13: Light-load direction detection completed																		
		14: Down as the light-load direction detection result																		
		15: Up as the light-load direction detection result																		
		16: Running 1 (excluding current withdrawal)																		
		17: STO operation																		
		18: SPI fault output																		
		19: UPS control signal output (for India)																		
		20: Reserved																		
P06.08	Polarity of output terminals	<p>The function code is used to set the pole of the output terminal.</p> <p>If the current bit is set to 0, output terminal is positive. If the current bit is set to 1, output terminal is negative.</p> <table border="1" style="margin-left: auto; margin-right: auto;"> <tr> <td></td> <td>BIT6</td> <td>BIT5</td> <td>BIT4</td> </tr> <tr> <td></td> <td>RO4</td> <td>RO3</td> <td>RO2</td> </tr> <tr> <td>BIT3</td> <td>BIT2</td> <td>BIT1</td> <td>BIT0</td> </tr> <tr> <td>RO1</td> <td>HDO</td> <td>Y2</td> <td>Y1</td> </tr> </table> <p>Setting range: 0x0–0x7F</p>		BIT6	BIT5	BIT4		RO4	RO3	RO2	BIT3	BIT2	BIT1	BIT0	RO1	HDO	Y2	Y1	00	<input type="radio"/>
	BIT6	BIT5	BIT4																	
	RO4	RO3	RO2																	
BIT3	BIT2	BIT1	BIT0																	
RO1	HDO	Y2	Y1																	
P06.09	AO1 output	0: Running speed	0	<input type="radio"/>																
		1: Set speed																		
P06.10	HDO high-speed pulse output	2: Running rotation speed	0	<input type="radio"/>																
		3: Output current																		
		4: Output voltage																		
		5: Output power																		
		6: Output torque																		
		7: AI1 input value																		
		8: AI2 input value																		
		9–14: Reserved																		
P06.11	AO1 output lower limit	The above function codes define the relative	0.0%	<input type="radio"/>																
P06.12	AO1 output of lower limit	relationship between the output value and	0.00V	<input type="radio"/>																

Function code	Name	Detailed instruction of parameters	Default value	Modify
P06.13	AO1 output upper limit	analog output. When the output value exceeds	100.0%	<input type="radio"/>
P06.14	AO1 output of upper limit	the range of set maximum or minimum output, it will count according to the low-limit or upper-limit	10.00V	<input type="radio"/>
P06.15	AO1 output filter time	output.	0.000s	<input type="radio"/>
P06.16	HDO output lower limit	When the analog output is current output, 1mA equals to 0.5V.	0.00%	<input type="radio"/>
P06.17	HDO output of lower limit	In different cases, the corresponding analog output of 100% of the output value is different.	0.0kHz	<input type="radio"/>
P06.18	HDO output upper limit	See each application for detailed information.	100.0%	<input type="radio"/>
P06.19	HDO output of upper limit		50.00kHz	<input type="radio"/>
P06.20	HDO output filter time	Setting range of <a href="#">P06.11</a> : -300.0%– <a href="#">P06.13</a> Setting range of <a href="#">P06.12</a> : -0.00V–10.00V Setting range of <a href="#">P06.13</a> : - <a href="#">P06.11</a> –300.0% Setting range of <a href="#">P06.14</a> : -0.00V–10.00V Setting range of <a href="#">P06.15</a> : -0.000s–10.000s Setting range of <a href="#">P06.16</a> : -300.0%– <a href="#">P06.18</a> Setting range of <a href="#">P06.17</a> : -0.00–50.00kHz Setting range of <a href="#">P06.18</a> : - <a href="#">P06.16</a> –300.0% Setting range of <a href="#">P06.19</a> : -0.00–50.00kHz Setting range of <a href="#">P06.20</a> : -0.000s–10.000s	0.000s	<input type="radio"/>
P06.21	Reserved	0–65535	0	<input type="radio"/>
P06.22	Reserved	0–65535	0	<input type="radio"/>
<b>P07 Group Human-machine interface</b>				
P07.00	User's password	0–65535	0	<input type="radio"/>
P07.01	Parameter copy	Ones place: 0: No operation 1: Upload function parameters to the keypad from machine 2: Download function parameters (including motor parameters) from the keypad to machine. 3: Download function parameters (excluding the motor parameters of <a href="#">P02</a> ) from the keypad to machine. 4: Download function parameters (including only motor parameters of <a href="#">P02</a> ) from the keypad to	0x100	<input checked="" type="radio"/>

Function code	Name	Detailed instruction of parameters	Default value	Modify
		<p>machine.</p> <p>5: Save function parameters (including motor parameters) of the machine</p> <p><b>Note:</b> After completing the 1–5 operations, the parameter is automatically reset to 0. The upload and download functions are invalid for the factory parameters in P29.</p> <p>Tens place: Indicates the parameter group to be uploaded or downloaded. You can set four groups.</p> <p>Thousands place: Indicates the response speed of the keypad</p> <p>0: Low speed 1: Medium speed 2: High speed</p>		
P07.02	Reserved	Reserved	0	⊙
P07.03	Keypad	<p>0: External keypad</p> <p>1: Local keypad</p> <p>2: Both external keypad and local keypad are valid.</p>	2	○
P07.04	QUICK/JOG function selection	<p>0: No function</p> <p>1: Reserved</p> <p>2: Shift the display state by the shifting key.</p> <p>3: Shift between forward rotations and reverse rotations.</p> <p>4: Clear UP/DOWN settings.</p> <p>5: Coast to stop.</p> <p>6: Reserved</p> <p>7: Quick commissioning mode (based on non-factory parameter settings)</p>	7	⊙
P07.05	STOP/RST function selection	<p>0: Only valid for the keypad control</p> <p>1: Valid for both keypad and terminals control</p> <p>2: Valid for both keypad and communication control</p> <p>3: Valid for all control modes</p>	0	○

Function code	Name	Detailed instruction of parameters	Default value	Modify
P07.06	Selection 1 of parameters displayed in running state	0x0000–0xFFFF Bit0: Running speed Bit1: Set speed Bit2: Bus voltage Bit3: Output voltage (V on) Bit4: Output current (A on) BIT5: Set frequency (Hz on) BIT6: Running frequency (Hz on) BIT7: Running rotation speed BIT8: Output power (% on) BIT9: Output torque (% on) BIT10: Input terminal state BIT11: Output terminal state BIT12: AI1 (% on) BIT13: AI2 (% on) BIT14: Magnetic pole position Bit15: Linear speed	0x07F	○
P07.07	Selection 2 of parameters displayed in running state	Reserved	0x0000	○
P07.08	Selection of parameters displayed in stop state	0x0000–0xFFFF BIT0: Set speed BIT1: Set frequency BIT2: Bus voltage BIT3: Input terminal state BIT4: Output terminal state BIT5: AI1 BIT6: AI2 BIT7: Magnetic pole position BIT8–BIT15: Reserved	0x007F	○
P07.09	Speed display coefficient	0.0–300.0%	100.0%	○
P07.10	Rectifier bridge module temperature	0–100.0°C	0.0	●
P07.11	Converter module temperature	0–100.0°C	0.0	●
P07.12	Software version	1.00–655.35	0.00	●
P07.13	Local accumulative running time (h)	0–65535h	0	●

Function code	Name	Detailed instruction of parameters	Default value	Modify
P07.14	Local accumulative running time (min)	0–60min	0	●
P07.15	MSB of local accumulative running count	0–65535 ( <a href="#">P07.15</a> ×10000 + <a href="#">P07.16</a> )	0	●
P07.16	LSB of Local accumulative running count	0–10000	0	●
P07.17	MSB of inverter power consumption	0–65535 kWh (×1000)	0	●
P07.18	LSB of inverter power consumption	0.0–999.9 kWh	0.0	●
P07.19	Inverter rated power	0.4–3000.0kW	0.0	●
P07.20	Inverter rated voltage	50–1200V	0	●
P07.21	Inverter rated current	0.1–6000.0A		●
P07.22	Factory bar code 1	0x0000–0xFFFF		●
P07.23	Factory bar code 2	0x0000–0xFFFF		●
P07.24	Factory bar code 3	0x0000–0xFFFF		●
P07.25	Factory bar code 4	0x0000–0xFFFF		●
P07.26	Factory bar code 5	0x0000–0xFFFF		●
P07.27	Factory bar code 6	0x0000–0xFFFF		●

Function code	Name	Detailed instruction of parameters	Default value	Modify
P07.28	Type of current fault	0: No fault 1: Inverter unit U phase protection (OUt1) 2: Inverter unit V phase protection (OUt2) 3: Inverter unit W phase protection (OUt3) 4: ACC overcurrent (OC1) 5: DEC overcurrent (OC2) 6: Constant-speed overcurrent (OC3) 7: ACC overvoltage (OV1) 8: DEC overvoltage (OV2) 9: Constant-speed overvoltage (OV3) 10: Bus undervoltage (UV) 11: Motor overload (OL1) 12: Inverter overload (OL2)		●
P07.29	Type of last fault	13: Input side phase loss (SPI) 14: Output side phase loss (SPO) 15: Overheat of the rectifier module (OH1) 16: Overheat fault of the converter module (OH2) 17: External fault (EF) 18: 485 communication fault (CE) 19: Current detection fault (ItE) 20: Motor autotune fault (tE) 21: EEPROM operation fault (EEP) 22: PID response offline fault (PIDE) 23: Brake unit fault (bCE)		●
P07.30	Type of last but one fault	24: Running time arrival (END) 25: Electrical overload (OL3)		●
P07.31	Type of last but two fault	26: Panel communication fault (PCE) 27: Parameter uploading fault (UPE) 28: Parameter downloading fault (DNE)		●
P07.32	Type of last but three fault	29: PROFIBUS communication fault (E-DP) 30: Ethernet communication fault (E-NET)		●
P07.33	Type of last but four	31: CANopen communication fault (E-CAN) 32: Grounding short circuit fault 1 (ETH1) 33: Grounding short circuit fault 2 (ETH2)		●
P07.34	Type of last but five fault	34: Speed deviation fault (dEu) 35: Maladjustment (STo) 36: Undervoltage fault (LL)		
P07.35	Type of last but six fault	37: Encoder offline fault (ENC1O) 38: Encoder reverse fault (ENC1D)		
P07.36	Type of last but seven fault	39: Encoder Z pulse offline fault (ENC1Z) 40: U disconnection (ENC1U)		

Function code	Name	Detailed instruction of parameters	Default value	Modify
P07.37	Previous 9 fault type	41–42: Reserved 43: Motor overtemperature fault (OT) 44: Reserved 45: Braking fault (BAE) 46: Contactor fault (CONE) 47: No CD signal (nPoS) 48: No enabling signal (U-EN) 49: STO card fault (SAFE) 50: Channel 1 (STO1_FB_DSP) safety circuit exception (STL1) 51: Channel 2 (STO1_FB_DSP) safety circuit exception (STL2) 52: Internal circuit exception (STL3) 53: Safety code FLASH CRC fault (CrCE)		
P07.38	Running frequency at current fault		0.00Hz	●
P07.39	Ramp reference frequency at current fault		0.00Hz	●
P07.40	Output voltage at current fault		0V	●
P07.41	Output current at current fault		0.0A	●
P07.42	Bus voltage at current fault		0.0V	●
P07.43	Max. temperature at current fault		0.0°C	●
P07.44	Input terminals state at current fault		0	●
P07.45	Output terminals state at current fault		0	●
P07.46	Running frequency at last fault		0.00Hz	●

Function code	Name	Detailed instruction of parameters	Default value	Modify
P07.47	Ramp reference frequency at last fault		0.00Hz	●
P07.48	Output voltage at last fault		0V	●
P07.49	Output current at last fault		0.0A	●
P07.50	Bus voltage at last fault		0.0V	●
P07.51	Max. temperature at last fault		0.0°C	●
P07.52	Input terminals state at last fault		0	●
P07.53	Output terminals state at last fault		0	●
P07.54	Running frequency at last fault		0.00Hz	●
P07.55	Ramp reference frequency at last but one fault		0.00Hz	●
P07.56	Output voltage at last but one fault		0V	●
P07.57	Output current at last but one fault		0.0A	●
P07.58	Bus voltage at last but one fault		0.0V	●
P07.59	Max. temperature at last but one fault		0.0°C	●
P07.60	Input terminals state at last but one fault		0	●

Function code	Name	Detailed instruction of parameters	Default value	Modify
P07.61	Output terminals state at last but one fault		0	●
P07.62	Reserved	0-65535	0	○
P07.63	Reserved	0-65535	0	○
<b>P08 Group Enhanced function</b>				
P08.00	Analogic weighing input	0: None 1: AI1	0	◎
P08.01	Pre-torque offset	0.0-100.0%	45.0%	○
P08.02	Gain at drive side	0.000-7.000	2.000	○
P08.03	Gain at braking side	0.000-7.000	2.000	○
P08.04	Brake close delay	0.00-5.00s	0.10s	◎
P08.05	Brake switch-off delay	0.00-5.00s	0.10s	◎
P08.06	Brake feedback detection time	0.0-5.0s	2.0s	◎
P08.07	Brake fault action	0: Report the fault and stop 1: Stop without fault reporting	0	◎
P08.08	Contacto r feedback detection time	0.00-5.00s	2.0s	◎
P08.09	Contacto r fault action	0: Report the fault and stop 1: Stop without fault reporting	0	◎
P08.10	Braking threshold voltage	320.0-750.0V	700.0V	○
P08.11	Auto fault reset count	0-10 (OUT and OC do not allow auto fault reset.)	0	○

Function code	Name	Detailed instruction of parameters	Default value	Modify
P08.12	Faulty relay action during auto fault reset	0x00–0x11 LED ones: 0: Action during undervoltage 1: No action during undervoltage LED tens: 0: Action during auto fault reset 1: No action during auto fault reset	0x00	<input type="radio"/>
P08.13	Auto fault reset interval	0.1–100.0s	0.1s	<input type="radio"/>
P08.14	Braking frequency during stop	0.00–5.00Hz	0.00Hz	<input type="radio"/>
P08.15	Inverter stop delay	0.00–5.00s	0.10s	<input checked="" type="radio"/>
P08.16	Current withdrawal time during stop	0.00–5.00s	0.20s	<input checked="" type="radio"/>
P08.17	Modulation	0: 2PH modulation 1: 3PH modulation	1	<input checked="" type="radio"/>
P08.18	Overmodulation validity	0: Invalid 1: Valid	1	<input checked="" type="radio"/>
P08.19	FDT1 electrical level detection value	0.00– <a href="#">P00.04</a> (max. frequency)	0.20Hz	<input type="radio"/>
P08.20	FDT1 lag detection value	0.0–100.0% (FDT1 electrical level)	0.0%	<input type="radio"/>
P08.21	Frequency arrival detection amplitude	0.00– <a href="#">P00.04</a> (max. frequency)	0.00Hz	<input type="radio"/>
P08.22	Cooling fan running mode	0: Normal mode 1: The fan keeps running after power on	0	<input type="radio"/>
P08.23	Enable light-load direction search	0: Disabled 1: Enable auto running 2: Enable the function of providing the running direction	0	<input checked="" type="radio"/>
P08.24	Light-load direction detection time	0.000–5.000s	2.000s	<input checked="" type="radio"/>

Function code	Name	Detailed instruction of parameters	Default value	Modify
P08.25	Enable short floor control	0: Disable 1: Enable	0	☉
P08.26	Short floor speed	0.0%–90.0% ( <a href="#">P00.02</a> )	40.0%	☉
P08.27	Short floor running time	0.00–20.00s	2. 00	☉
P08.28	Contactors disconnection delay	0.00–10.00s	2.00s	☉
P08.29	Enable Keb sequence	0: Disabled 1: Enabled	0	○
P08.30	Open-loop start brake open frequency of asynchronous motor	0.00–5.00 Hz	0.00 Hz	○
<b>P09 Group Speed curve setting</b>				
P09.00	Multi-step speed 0	0.000– <a href="#">P00.02</a>	0.000m/s	☉
P09.01	Multi-step speed 1	0.000– <a href="#">P00.02</a>	0.000m/s	☉
P09.02	Multi-step speed 2	0.000– <a href="#">P00.02</a>	0.000m/s	☉
P09.03	Multi-step speed 3	0.000– <a href="#">P00.02</a>	0.000m/s	☉
P09.04	Multi-step speed 4	0.000– <a href="#">P00.02</a>	0.000m/s	☉
P09.05	Multi-step speed 5	0.000– <a href="#">P00.02</a>	0.000m/s	☉
P09.06	Multi-step speed 6	0.000– <a href="#">P00.02</a>	0.000m/s	☉
P09.07	Multi-step speed 7	0.000– <a href="#">P00.02</a>	0.000m/s	☉

Function code	Name	Detailed instruction of parameters	Default value	Modify
P09.08	Multi-step speed priority	0: CHINESE TYPE 1: ISTANBUL TYPE 2: KONYA TYPE 3: ADANA TYPE	0	⊙
P09.09	S-curve ACC start segment duration	0.1–360.0s	2.0	⊙
P09.10	S-curve ACC end segment duration	0.1–360.0s	2.0	⊙
P09.11	ACC time	0.1–360.0s	2.0	⊙
P09.12	S-curve DEC start segment duration	0.1–360.0s	2.0	⊙
P09.13	S-curve DEC end segment duration	0.1–360.0s	2.0	⊙
P09.14	DEC time	0.1–360.0s	2.0	⊙
P09.15	S-curve start segment duration during stop	0.1–360.0s	2.0	⊙
P09.16	S-curve end segment duration during stop	0.1–360.0s	2.0	⊙
P09.17	Running speed at maintenance	0.001 – <a href="#">P00.02</a>	0.200m/s	⊙
P09.18	ACC/DEC time at maintenance	0.1–360.0s	4.0s	⊙
P09.19	Forced DEC time	0.1–360.0s	2.0s	⊙
P09.20	Emergency running speed	0.001 – <a href="#">P00.02</a>	0.100 m/s	⊙
P09.21	Emergency ACC/DEC time	0.1–360.0s	20.0s	⊙
P09.22	Leveling segment	0–7	0	⊙
P09.23	Leveling speed	0.001 – <a href="#">P00.02</a>	0.010m/s	⊙

Function code	Name	Detailed instruction of parameters	Default value	Modify
P09.24	DEC time for creeping to stop	0.1–360.0s During deceleration to stop, when the speed reached the value set in <a href="#">P01.12</a> , the curve of deceleration to stop switches to those set in <a href="#">P09.15</a> , <a href="#">P09.16</a> , and <a href="#">P09.24</a> .	2.0s	<input type="radio"/>
P09.25	Speed threshold for light-load detection in open-loop control	5.00–20.00 Hz	5.00 Hz	<input type="radio"/>
<b>P10 Group Non-weighing compensation</b>				
P10.00	Enable non-weighing compensation	0: Disable 1: Enable	0	<input checked="" type="radio"/>
P10.01	Load compensation time	0.000–5.000s	0.400	<input checked="" type="radio"/>
P10.02	Load compensation decrease time	0.000–5.000s	0.100	<input checked="" type="radio"/>
P10.03	Load compensation ASR gain	0–100.0	25.0	<input type="radio"/>
P10.04	Load compensation ASR integral time	0.01–10.000s	0.160	<input type="radio"/>
P10.05	Load compensation current coefficient KP	0–1000	1000	<input type="radio"/>
P10.06	Load compensation current coefficient KI	0–1000	0	<input type="radio"/>
P10.07	APR gain	0–100.0	0.0	<input type="radio"/>
P10.08	APR integral time	0.001–10.000s	0.001	<input type="radio"/>

Function code	Name	Detailed instruction of parameters	Default value	Modify
P10.09	Current loop filter coefficient	Bit0–2: Current instruction filter count (compensation completion phase) Bit3-5: Current instruction filter count (compensation phase) Bit6: Speed detection switching( 0: segmentation; 1 observer) Bit7-8: Current sampling filter count Bit14: Enable temperature-based carrier frequency decrease (0: Enable; 1: Disable) Bit2–15: Reserved	0	<input type="radio"/>
P10.10	Reserved	0–65535	0	<input type="radio"/>
P10.11	Reserved	0–65535	0	<input type="radio"/>
<b>P11 Group Protective parameters</b>				
P11.00	Phase loss protection	0x000–0x111 LED ones: 0: Disable input phase loss protection 1: Enable input phase loss protection LED tens: 0: Disable output phase loss protection 1: Enable output phase loss protection LED hundreds: 0: Disable hardware input phase loss protection 1: Enable hardware input phase loss protection	0x110	<input type="radio"/>
P11.01	Frequency-decreasing at sudden power loss	0: Disable 1: Enable	0	<input type="radio"/>

Function code	Name	Detailed instruction of parameters	Default value	Modify						
P11.02	Frequency decreasing ratio at sudden power loss	<p>Setting range: 0.00Hz/s–<a href="#">P00.04</a> (max. output frequency)</p> <p>After the power loss of the grid, the bus voltage drops to the sudden frequency-decreasing point, the inverter begin to decrease the running frequency at <a href="#">P11.02</a>, to make the inverter generate power again. The returning power can maintain the bus voltage to ensure a rated running of the inverter until the recovery of power.</p> <table border="1" data-bbox="449 571 758 687"> <tr> <td>Voltage degree</td> <td>380V</td> <td>660V</td> </tr> <tr> <td>Frequency-decreasing threshold</td> <td>460V</td> <td>800V</td> </tr> </table> <p><b>Note:</b></p> <ol style="list-style-type: none"> <li>Adjust the parameter properly to avoid the stopping caused by inverter protection during the switching of the grid.</li> <li>Disable input phase loss protection to enable this function.</li> </ol>	Voltage degree	380V	660V	Frequency-decreasing threshold	460V	800V	10.00Hz /s	<input type="radio"/>
Voltage degree	380V	660V								
Frequency-decreasing threshold	460V	800V								
P11.03	Overvoltage stall protection	0: Disable 1: Enable	0	<input type="radio"/>						
P11.04	Voltage protection of overvoltage stall	120–150% (standard bus voltage) (380V)	136%	<input type="radio"/>						
P11.05	Current limit action selection	<p>The actual increasing ratio of motor speed is lower than the ratio of output frequency because of the big load during ACC running. It is necessary to take measures to avoid overcurrent fault and the inverter trips.</p> <p>Ones: current limit setting</p> <p>0: Invalid 1: Always valid</p>	0	<input checked="" type="radio"/>						
P11.06	Automatic current limit	During the running of the inverter, it will detect	160.0%	<input checked="" type="radio"/>						

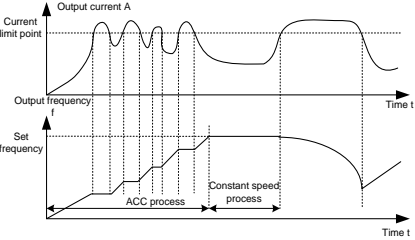
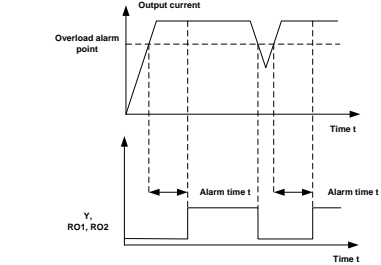
Function code	Name	Detailed instruction of parameters	Default value	Modify
P11.07	Frequency-decreasing ratio during current limit	<p>the output current and compare it with the limit level defined in <a href="#">P11.06</a>. If it exceeds the level, the inverter will run at stable frequency in ACC running, or the inverter will derate to run during the constant running. If it exceeds the level continuously, the output frequency will keep on decreasing to the lower limit. If the output current is detected to be lower than the limit level, the inverter will accelerate to run.</p>  <p>Setting range of <a href="#">P11.06</a>: 50.0–200.0%</p> <p>Setting range of <a href="#">P11.07</a>: 0.00–50.00Hz/s</p>	10.00Hz /s	☉
P11.08	Inverter/motor overload alarm	<p>The output current of the inverter or the motor is above <a href="#">P11.09</a> and the lasting time is beyond <a href="#">P11.10</a>, overload alarm will be output.</p>	0x000	○
P11.09	Overload alarm detection	 <p><a href="#">P11.08</a>: Enable and define the inverter/motor</p>	Model G: 150%	○

Function code	Name	Detailed instruction of parameters	Default value	Modify
P11.10	Overload alarm detection time	<p>overload alarm function.</p> <p>Setting range: 0x000–0x131</p> <p>LED ones:</p> <p>0: Motor overload alarm, relative to the rated current of the motor</p> <p>1: Inverter overload alarm, relative to the rated current of the inverter</p> <p>LED tens:</p> <p>0: The inverter continues working after overload/underload alarm.</p> <p>1: The inverter continues working after underload alarm reporting but it stops running upon an overload fault.</p> <p>2: The inverter continues working after overload alarm reporting but it stops running upon an underload fault.</p> <p>3: The inverter stops running after overload/underload alarm reporting.</p> <p>LED hundreds:</p> <p>0: Detection all the time</p> <p>1: Detection in constant running</p> <p>Setting range of <a href="#">P11.09</a>: 100%–200%</p> <p>Setting range of <a href="#">P11.10</a>: 0.1–3600.0s</p>	1.0s	<input type="radio"/>
P11.11	Motor overload selection	<p>0: No protection</p> <p>1: Common motor</p> <p>2: Variable-frequency motor</p>	2	<input checked="" type="radio"/>
P11.12	Motor overload protection coefficient	20.0%–120.0%	100.0	<input type="radio"/>
P11.13	Speed deviation detection	0.0–50.0%	10.0%	<input type="radio"/>
P11.14	Speed deviation detection time	<p>This parameter is used to set the speed deviation detection time.</p> <p>Note: Speed deviation protection is disabled when <a href="#">P11.14</a> is set to 0.0.</p>	1.0s	<input type="radio"/>

Function code	Name	Detailed instruction of parameters	Default value	Modify
		<p>Setting range: 0.0-10.0s</p>		
P11.15	Emergency operation undervoltage point	0.0-1000.0V	200.0v	☉
P11.16	Operation when no enabling signal is found	0: Immediately report the fault and stop 1: Report the fault after stop	0	☉
P11.17	Enabling signal delay detection time	0.0-10.0s (running time before an enabling signal delay is detected)	0.1	○
<b>P12 Group Motor parameters 2 (reserved)</b>				
<b>P13 Group Synchronous motor control (reserved)</b>				
<b>P14 Group Serial and CAN communication</b>				
P14.00	Local communication address	<p>Setting range: 1-247</p> <p>If the slave communication address is set to 0 when the master is writing the frame, the address is the communication address. All slaves on the MODBUS fieldbus can receive the frame, but the slaves do not answer. The local communication address is unique in the communication network. This is the fundamental for the point to point communication between the upper monitor and the inverter.</p> <p>Note: The slave address cannot set to 0.</p>	1	○

Function code	Name	Detailed instruction of parameters	Default value	Modify
P14.01	Communication baud ratio	<p>Sets the digital transmission speed between the upper monitor and the inverter.</p> <p>0: 1200BPS 1: 2400BPS 2: 4800BPS 3: 9600BPS 4: 19200BPS 5: 38400BPS 6: 57600BPS 7: 115200BPS</p> <p><b>Note:</b> The baud rate between the upper PC and the inverter must be the same. Otherwise, the communication is not applied. The bigger the baud rate, the quicker the communication speed.</p>	4	○
P14.02	Digital bit check	<p>The data format between the upper monitor and the inverter must be the same. Otherwise, the communication fails.</p> <p>0: No check (N,8,1) for RTU 1: Even check (E,8,1) for RTU 2: Odd check (O,8,1) for RTU 3: No check (N,8,2) for RTU 4: Even check (E,8,2) for RTU 5: Odd check(O,8,2) for RTU</p>	1	○
P14.03	Answer delay	<p>0–200ms</p> <p>The interval time when the drive receives the data and sent it to the upper monitor. If the answer delay is shorter than the system processing time, then the answer delay time is the system processing time, if the answer delay is longer than the system processing time, then after the system deal with the data, waits until achieving the answer delay time to send the data to the upper monitor.</p>	5	○

Function code	Name	Detailed instruction of parameters	Default value	Modify
P14.04	Communication timeout fault duration	0.0 (invalid), 0.1–60.0s When the function code is set as 0.0, the parameter is invalid. When the function code is set as non-zero, if the interval time between two communications exceeds this parameter value, the system will report "485 communication faults" (CE). Generally, set it as invalid; set the parameter in the continuous communication to monitor the communication state.	0.0s	<input type="radio"/>
P14.05	Transmission fault processing	0: Alarm and stop freely 1: No alarm and continue to run 2: No alarm and stop according to the stop mode (only under the communication control) 3: No alarm and stop according to the stop mode (under all control modes)	0	<input type="radio"/>
P14.06	Communication processing	0x00–0x11 LED ones: 0: Write with response: the inverter will respond to all reading and writing commands of the upper monitor. 1: Write without response: the inverter only responds to the reading command other than the writing command of the drive. The communication efficiency can be increased by this method. LED tens: 0: Communication encrypting invalid 1: Communication encrypting valid	0x00	<input type="radio"/>
P14.07	CAN communication address	0–127 (0 is a broadcast address, indicating that messages are sent but not replied)	2	<input type="radio"/>

Function code	Name	Detailed instruction of parameters	Default value	Modify
P14.08	CAN communication rate	0: 50 k 1: 100 k 2: 125 k 3: 250 k 4: 500 k	0	<input type="radio"/>
P14.09	CAN communication error time	0.0–10.0s	1.0	<input type="radio"/>
P14.10	Reserved	0–65535	0	<input type="radio"/>
P14.11	Reserved	0–65535	0	<input type="radio"/>
<b>P15 Group Bluetooth communication</b>				
P15.00	Expansion card type	0: No 1: STO 2: IO 3: Bluetooth	1	<input checked="" type="radio"/>
P15.01	STO function setting	0: STO alarm locked (the SAFE fault can be reset) Alarm locking refers to that after a SAFE fault occurs and the state is restored, you need to manually reset. 1: STO alarm not locked No alarm locking refers to that after a SAFE fault occurs and the state is restored, the alarm is automatically deleted. <b>Note:</b> All of STL1 to STL3 faults are set to alarm locked, and cannot be reset. After the state is restored, you need to apply power again for reset.	0	<input type="radio"/>
P15.02	Reserved	0 - 65535		<input type="radio"/>
P15.03	Reserved	0 - 65535		<input type="radio"/>
P15.04	Reserved	0 - 65535		<input type="radio"/>
P15.05	Reserved	0 - 65535		<input type="radio"/>
<b>P16 Group Ethernet communication</b>				
P16.00	Ethernet communication speed	0: Self-adapting 1: 100M full duplex 2: 100M semiduplex 3: 10M full duplex 4: 10M semiduplex	3	<input checked="" type="radio"/>

Function code	Name	Detailed instruction of parameters	Default value	Modify
		The function code is used to set the Ethernet communication speed.		
P16.01	IP address 1	0–255	192	☉
P16.02	IP address 2	Set the IP addresses in Ethernet communication.	168	☉
P16.03	IP address 3	IP address format: <a href="#">P16.01</a> . <a href="#">P16.02</a> . <a href="#">P16.03</a> . <a href="#">P16.04</a>	28	☉
P16.04	IP address 4	IP address example: 192.168.0.1	11	☉
P16.05	Subnet mask 1	0–255	255	☉
P16.06	Subnet mask 2	Set the subnet masks in Ethernet communication.	255	☉
P16.07	Subnet mask 3	Subnet mask format: <a href="#">P16.05</a> . <a href="#">P16.06</a> . <a href="#">P16.07</a> . <a href="#">P16.08</a>	255	☉
P16.08	Subnet mask 4	Subnet mask example: 255.255.255.0	0	☉
P16.09	Gateway 1	0–255 Set the gateways in Ethernet communication.	192	☉
P16.10	Gateway 2		168	☉
P16.11	Gateway 3		28	☉
P16.12	Gateway 4		1	☉
P16.13	Reserved	0 – 65535	0	●
P16.14	Reserved	0 – 65535	0	●
<b>P17 Group Monitoring function</b>				
P17.00	Set frequency	Display current set frequency of the inverter Setting range: 0.00Hz– <a href="#">P00.04</a>	0.00Hz	●
P17.01	Output frequency	Display the current output frequency of the inverter. Setting range: 0.00Hz– <a href="#">P00.04</a>	0.00Hz	●
P17.02	Ramp reference frequency	Display current ramp given frequency of the inverter. Setting range: 0.00Hz– <a href="#">P00.04</a>	0.00Hz	●
P17.03	Output voltage	Display current output voltage of the inverter. Setting range: 0–1200V	0V	●
P17.04	Output current	Display current output current of the inverter. Setting range: 0.0–5000.0A	0.0A	●

Function code	Name	Detailed instruction of parameters	Default value	Modify																				
P17.05	Motor speed	Display the rotation speed of the motor. Setting range: 0–65535RPM	0 RPM	●																				
P17.06	Torque current	Display current torque current of the inverter. Setting range: -3000.0–3000.0A	0.0A	●																				
P17.07	Exciting current	Display current exciting current of the inverter. Setting range: -3000.0–3000.0A	0.0A	●																				
P17.08	Motor power	Display current power of the motor. Setting range: -300.0–300.0% (relative to the motor rated power), 0.0% (relative to the motor rated power)	0.0%	●																				
P17.09	Output torque	Display the current output torque of the inverter. Setting range: -250.0–250.0%%	0.0%	●																				
P17.10	Evaluated motor frequency	Evaluate the motor rotor frequency on close loop vector. Setting range: 0.00– <a href="#">P00.04</a>	0.00Hz	●																				
P17.11	DC bus voltage	Display current DC bus voltage of the inverter. Setting range: 0.0–2000.0V	0V	●																				
P17.12	Digital input terminals state	Display current Switch input terminals state of the inverter. <table border="1" style="margin: 10px auto;"> <tr> <td></td> <td>BIT8</td> <td>BIT7</td> <td>BIT6</td> <td>BIT5</td> </tr> <tr> <td></td> <td>HDI</td> <td>S8</td> <td>S7</td> <td>S6</td> </tr> <tr> <td>BIT4</td> <td>BIT3</td> <td>BIT2</td> <td>BIT1</td> <td>BIT0</td> </tr> <tr> <td>S5</td> <td>S4</td> <td>S3</td> <td>S2</td> <td>S1</td> </tr> </table> Setting range: 0000–03FF		BIT8	BIT7	BIT6	BIT5		HDI	S8	S7	S6	BIT4	BIT3	BIT2	BIT1	BIT0	S5	S4	S3	S2	S1	0	●
	BIT8	BIT7	BIT6	BIT5																				
	HDI	S8	S7	S6																				
BIT4	BIT3	BIT2	BIT1	BIT0																				
S5	S4	S3	S2	S1																				
P17.13	Digital output terminals state	Display current Switch output terminals state of the inverter. <table border="1" style="margin: 10px auto;"> <tr> <td>BIT3</td> <td>BIT2</td> <td>BIT1</td> <td>BIT0</td> </tr> <tr> <td>RO2</td> <td>RO1</td> <td>HDO</td> <td>Y</td> </tr> </table> Setting range: 0000–000F	BIT3	BIT2	BIT1	BIT0	RO2	RO1	HDO	Y	0	●												
BIT3	BIT2	BIT1	BIT0																					
RO2	RO1	HDO	Y																					
P17.14	AI1 input voltage	Display analog AI1 input signal. Setting range: 0.00–10.00V	0.00	●																				
P17.15	AI2 input voltage	Display analog AI2 input signal. Setting range: 0.00–10.00V	0.00	●																				
P17.16	HDI input frequency	Display HDI input frequency. Setting range: 0.000–50.000kHz	0.000K Hz	●																				

Function code	Name	Detailed instruction of parameters	Default value	Modify
P17.17	ASR controller output	Display ASR controller output in vector control mode, relative to the percentage of the motor rated torque. Setting range: -300.0%–300.0% (motor rated current)	0.0%	●
P17.18	Actual frequency detected by the encoder	Actual frequency detected by the encoder. If the motor rotates forward, the value is positive; if the motor rotates reverse, the value is negative. Setting range: -3276.8–3276.7Hz	0.00Hz	●
P17.19	Encoder pulse count	Position counting of the encoder, 4 times of the frequency Setting range: 0–65535	0	●
P17.20	Encoder Z-pulse count	Setting range: 0–65535	0	●
P17.21	Magnetic pole position angle	Setting range: 0.00–359.99	0. 00	●
P17.22	Initial magnetic pole position angle	Relative angle between the encoder position and motor magnetic pole position. Setting range: 0.00–359.99	0.00	●
P17.23	Encoder C-phase AD value	Sine-cosine encoder C-signal amplitude 0–4095	0	●
P17.24	Encoder D-phase AD value	Sine-cosine encoder D-signal amplitude 0–4095	0	●
P17.25	Motor pole pairs	Display the number of motor pole pairs. 0–65535	0	●
P17.26	Function code of function parameter upload/download fault	Function codes of faults that occur during function parameter upload or download 0.00–29.00	0	●
P17.27	Reserved	0–65535		●
P17.28	Reserved	0–65535		●
<b>P18 Group Reserved</b>				

Function code	Name	Detailed instruction of parameters	Default value	Modify
<b>P19 Group Reserved</b>				
<b>P20 Group Encoder</b>				
P20.00	Encoder type	0: Incremental encoder (AB) 1: ABZUVW encoder 2: Rotary transformer encoder 3: Sin/Cos encoder without CD signals 4: Sin/Cos encoder with CD signals 5: EnDat	0	☉
P20.01	Pulse quantity	Pulse number when the encoder rotates a circle. Setting range: 0–60000	1024	☉
P20.02	Encoder direction	Ones: AB direction 0: Forward 1: Reverse Tens: Reserved Hundreds place: CD (UVW) magnetic signal direction 0: Forward 1: Reverse	0x000	☉
P20.03	Offline detection time	Detection time of encoder offline fault. Setting range: 0.0–10.0s	1.0s	○
P20.04	Encoder reverse fault detection time	Detection time of encoder reverse fault. Setting range: 0.0–100.0s	0.8s	○
P20.05	Filter times	Setting range: 0x000–0x999 Ones: filter times at low speed, corresponding to $2^{(0-9)} \times 125\mu\text{s}$ Tens: filter times at high speed, corresponding to $2^{(0-9)} \times 125\mu\text{s}$ Hundreds: segmented speed detection filter, corresponding to $2^{(0-9)} \times 125\mu\text{s}$	0x133	○
P20.06	Speed ratio of motor and encoder	It is necessary to set the parameter when the encoder does not install on the motor shaft and the drive ratio is not 1. Setting range: 0.001–65.535	1.000	○
P20.07	Synchronous motor control parameters	Setting range: 0x0000–0xFFFF Bit0: Enable Z-pulse correction Bit1: Enable encoder angle correction Bit2: Enable SVC speed detection Bit3: Rotary transformer speed detection mode Bit4: Z-pulse capture mode Bit5: V/F control without detecting initial encoder angle	1	○

Function code	Name	Detailed instruction of parameters	Default value	Modify
		Bit6: Enable CD signal correction Bit7: Disable sin/cos segmented speed detection Bit8: Autotuning without detecting encoder faults Bit9: Enable Z-pulse detection optimization Bit10: Disable Z-pulse correction optimization Bit12: Stop and clear the Z-pulse arrival signal		
P20.08	Offline detection enabling of Z pulse	Z pulse offline fault is ENC1Z. Z pulse detection can be enabled to avoid wrong stopping or control loss which is caused by Z pulse loss when spindle stopping or incremental encoder is used in SM control. 0: Disable 1: Enable	0	○
P20.09	Initial angle of Z-pulse	Relative angle of encoder Z pulse to motor magnetic position. Setting range: 0.00–359.99	0	○
P20.10	Pole initial angle	Relative angle of encoder position to motor magnetic position. Setting range: 0.00–359.99	0	○
P20.11	Reserved	Reserved	0	◎
P20.12	Speed optimization enabling	0: Disable 1: Enable	1	○
P20.13	CD signal gain	0.80–1.20	1.00	◎
P20.14	C signal bias	0–4095	2048	◎
P20.15	D signal bias	0–4095	2048	◎
P20.16	Reserved	0–65535	0	○
P20.17	Reserved	0–65535	0	○
<b>P21 Group Distance control</b>				
P21.00	Enable distance control	0x00 - 0x11 Ones place: Enable control over the distance between high-speed running and creeping 0: Disabled; 1: Enabled Tens place: Enable control over the distance between creeping and stop 0: Disabled; 1: Enabled	0	◎

Function code	Name	Detailed instruction of parameters	Default value	Modify
P21.01	High-speed running DEC distance	0.200-3.000m	1.800	⊙
P21.02	Medium- and low-speed DEC distance	0.100-3.000m	1.000	⊙
P21.03	DEC distance for creeping to stop	0.010-1.000m	0.080	⊙
P21.04	UP DEC adjustment distance	-0.300 - 0.300m	0.000	⊙
P21.05	Down DEC adjustment distance	-0.300 - 0.300m	0.000	⊙
P21.06	High-speed step of multi-step speed running	0 - 7	3	⊙
P21.07	Medium- and low-speed step of multi-step speed running	0 - 7	1	⊙
P21.08	Creeping step of multi-step speed running	0 - 7	0	⊙

## 7 Commissioning guidelines

### 7.1 What this chapter contains

This chapter describes the commissioning guidelines for GD300L inverters special for lifts.

The commissioning process is as follows.

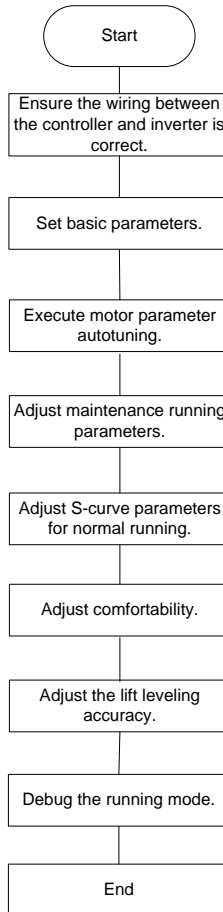

Figure 7-1 Commissioning process

## 7.2 Wiring between the lift controller and inverter

### 7.2.1 Wiring for the multi-step speed running mode

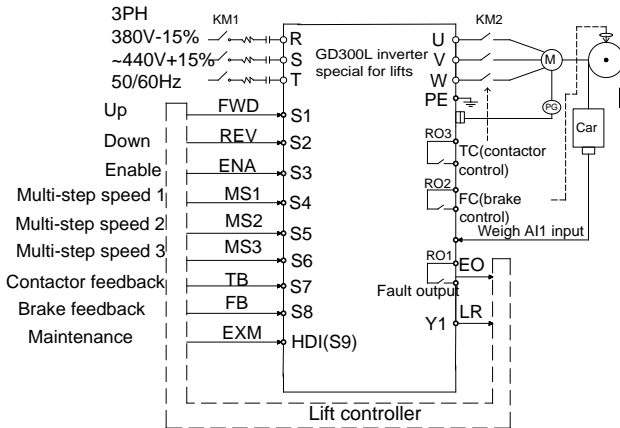

Figure 7-2 Typical wiring for the multi-step speed running mode

### 7.2.2 Wiring for the analog speed running mode

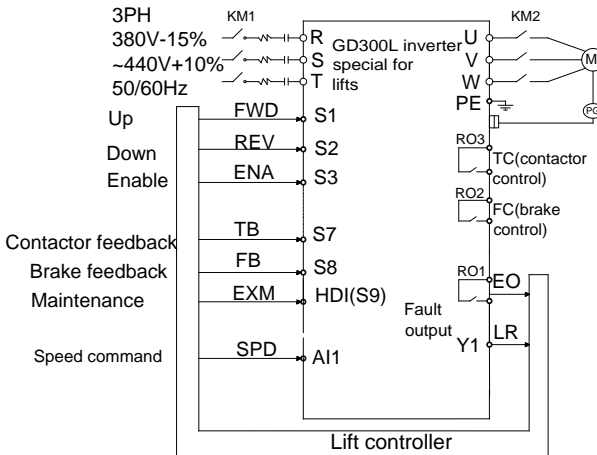

Figure 7-3 Wiring for the analog speed running mode

## 7.3 Setting basic parameters

After correct wiring, set application parameters as required. Pay high attention to the parameters related to peripheral electrical wiring, such as operation mode, control mode, programmable input/output setting, and feedback selection. Perform commissioning only after these parameters are correctly set. The table below lists the basic parameters.

Function code	Name	Recommended	Remarks
<a href="#">P00.00</a>	Speed control mode	0 or 3	0: Open-loop control for asynchronous motors; 3: Closed-loop control for synchronous motors
<a href="#">P00.01</a>	Running command channel	1	
<a href="#">P00.02</a>	Lift rated speed	Based on lift speed	
<a href="#">P00.03</a>	Speed command	3	
<a href="#">P00.04</a>	Max. output frequency	50.00Hz	
<a href="#">P02.00</a>	Motor type	Based on the motor.	
<a href="#">P02.01</a>	Motor rated power	Tractor parameter name plate	
<a href="#">P02.02</a>	Motor rated frequency	Tractor parameter name plate	
<a href="#">P02.03</a>	Motor rated rotation speed	Tractor parameter name plate	
<a href="#">P02.04</a>	Motor rated voltage	Tractor parameter name plate	
<a href="#">P02.05</a>	Motor rated current	Tractor parameter name plate	
<a href="#">P20.00</a>	Encoder type	0	
<a href="#">P20.01</a>	Encoder pulse quantity	Based on the encoder model	
<a href="#">P20.02</a>	Encoder direction	0	
<a href="#">P05.01</a>	S1	1	Up
<a href="#">P05.02</a>	S2	2	Down
<a href="#">P05.03</a>	S3	19	Enable
<a href="#">P05.04</a>	S4	8	Multi-step speed 1
<a href="#">P05.05</a>	S5	9	Multi-step speed 2
<a href="#">P05.06</a>	S6	10	Multi-step speed 3
<a href="#">P05.07</a>	S7	17	Contact feedback
<a href="#">P05.08</a>	S8	18	Brake feedback
<a href="#">P05.12</a>	HDI	3	Maintenance
<a href="#">P06.01</a>	Y output	1	Running feedback output
<a href="#">P06.04</a>	RO1 relay output	4	Fault output

Function code	Name	Recommended	Remarks
<a href="#">P06.05</a>	RO2 relay output	7	Brake output
<a href="#">P06.06</a>	RO3 relay output	8	Contactora output

## 7.4 Debugging running

After parameters are correctly set, debug running, including adjusting motor parameter autotuning, maintenance running, S curve for normal running, comfortability at startup or stop, and lift leveling accuracy.

### 7.4.1 Motor parameter autotuning

The control performance of the inverter is based on the established accurate motor model. You have to carry out the motor autotune before first running. Set the inverter to use the keypad control mode ([P00.01](#)=0), and execute parameter autotuning by using the method described in [P00.09](#). The figure below describes the autotuning process which takes motor 1 for example.

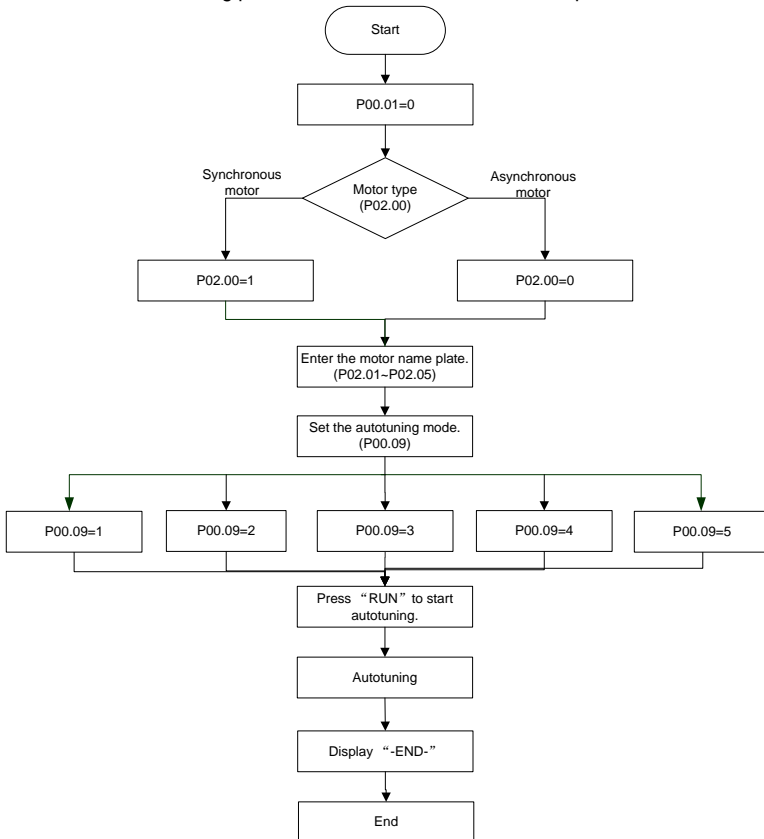

Figure 7-4 Motor parameter autotuning

**Note:**

- Set the motor parameters according to the motor name plate.
- Note the difference in synchronous and asynchronous motor parameter autotuning modes.

**7.4.2 Adjusting maintenance running parameters**

Maintenance running can be used to check whether the lift is running properly.

During maintenance, check whether the actual lift running direction is the same as the direction in the command. If not, exchange any two cables of U, V, and W or set [P00.06](#)=1.

**Note:** For the synchronous motor, changing the motor cables requires autotuning the motor parameter (pole angle) again. It is recommended to set [P00.06](#) to change the lift running direction.

**7.4.3 Adjusting the S curve for normal running**

Before normal running, check whether the control logic is correct and wiring is correct. If they are correct, adjust the S curve. For details, see the descriptions of [P09.09–P09.16](#).

Function code	Name	Setting range
<a href="#">P01.01</a>	Starting frequency of direct startup	0.00–50.00 [0.00Hz]
<a href="#">P01.03</a>	Starting frequency retention time	0.0–50.0 [0.0s]
<a href="#">P01.12</a>	Stop knee-point frequency	0.00 - 10.00 [1.00Hz]
<a href="#">P09.09</a>	S-curve ACC start segment duration	0.1–360.0 [2.0s]
<a href="#">P09.10</a>	S-curve ACC end segment duration	0.1–360.0 [2.0s]
<a href="#">P09.11</a>	ACC time	0.1–360.0 [2.0s]
<a href="#">P09.12</a>	S-curve DEC start segment duration	0.1–360.0 [2.0s]
<a href="#">P09.13</a>	S-curve DEC end segment duration	0.1–360.0 [2.0s]
<a href="#">P09.14</a>	DEC time	0.1–360.0 [2.0s]
<a href="#">P09.15</a>	S-curve start segment duration during stop	0.1–360.0 [2.0s]
<a href="#">P09.16</a>	S-curve end segment duration during stop	0.1–360.0 [2.0s]
<a href="#">P09.24</a>	DEC time for creeping to stop	0.1–360.0 [2.0s]

[P09.09–P09.16](#) determine the S-curve shape. The S-curve quality directly impacts the comfortability of the lift at startup or stop. The S-curve parameters are listed in the table above. Figure 7-5 describes the relationship between these parameters and S-curve.

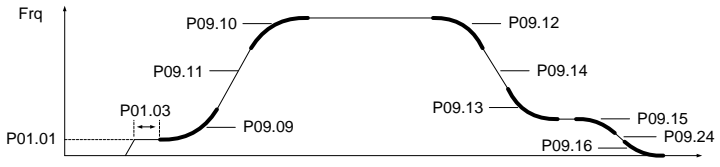

Figure 7-5 S-curve running

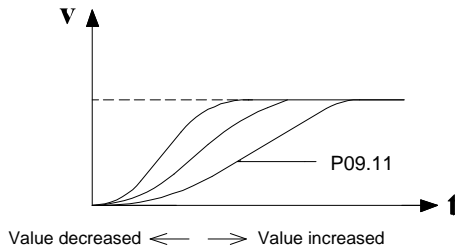

Figure 7-6 S-curve adjusting

Figure 7-6 describes the ACC segment S-curve parameter adjustment, in which the S curve changes sharply when the time decreases but the S curve changes slightly when the time increases. The adjustment principle of the DEC segment S-curve parameters and stop segment S-curve parameters are similar to that for the ACC segment S-curve parameters.

[P01.01](#) indicates the initial frequency during inverter startup. During inverter running, if the set speed (frequency) is less than the starting frequency of startup, the inverter output frequency is 0. Only when the set speed (frequency) is greater than or equal to the starting frequency, the inverter starts at the starting frequency and runs according to the S curve. Setting a proper starting frequency can reduce startup impact by overcoming the static friction during startup.

[P01.03](#) indicates the starting frequency retention time during inverter startup.

**Note:** [P09.09–P09.16](#) are key S-curve parameters, impacting passenger comfortability during ACC, DEC, and stop.

#### 7.4.4 Adjusting comfortability during startup or stop

Startup comfortability can be adjusted by setting the following function codes: [P01.01](#), [P01.03](#), [P09.09](#), [P09.10](#), [P09.11](#), [P03.00](#), [P03.01](#), and [P08.05](#). If the analog weighing equipment is used, startup pre-torque compensation must be adjusted. For details, see the descriptions of the function codes.

Stop comfortability can be adjusted by setting the following function codes: [P09.15](#), [P09.16](#), [P03.00](#), [P03.01](#), and [P08.04](#).

#### 7.4.5 Adjusting lift leveling accuracy

If floors are different in the leveling error, adjust each position of flashboard to keep the same errors

on every floor, and adjust creeping speed of elevator (set by multi-step speed) and [P09.16](#) (stop S-curve end segment duration).

## 7.5 Lift running mode

There are two running modes for GD300L: multi-step speed and analog quantity speed. The multi-step speed mode is mainly used.

### 7.5.1 Multi-step speed mode (brake and contactor are inverter controlled)

In multi-step speed mode, the speed command can be selected by external multi-step terminals. See Figure 7-2 for the wiring diagram. Brake and contractor are inverter controlled. Detecting the brake, contactor feedback signal, and maintenance command are controlled by input terminal (EXM). Run speeds are given by MS1–MS3 and the analog quantity of weighing equipment are applied.

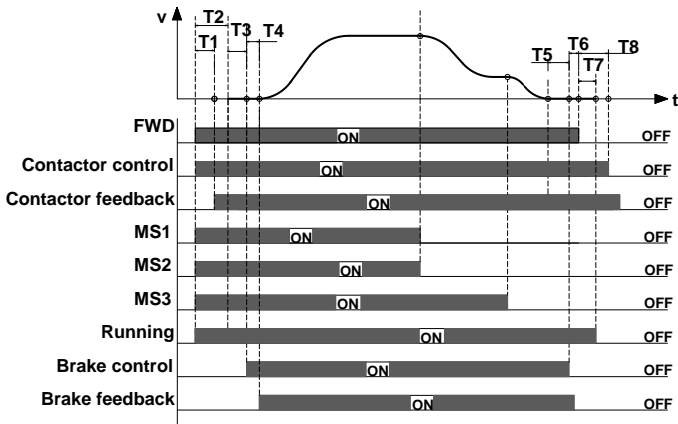

Figure 7-7 Lift multi-step speed running sequence chart

Running sequence description:

1. After receiving the FWD and MS1–MS3 commands from the controller, the inverter sends the contactor actuation command and outputs the running signal.
2. After T1, the inverter detects the contactor actuation feedback.
3. With the delay of T2 after receiving the running command, the inverter starts zero-speed output.
4. The inverter sends the brake control signal with the delay of T3.
5. After T4, the inverter detects the brake is completely open and then starts ACC at the starting frequency.
6. After the controller switches off the speed command (MS1–MS3), the inverter decelerates to stop according to the S curve. If the frequency reaches [P08.14](#), the inverter outputs the brake switch-off command with the delay of T5, requiring the controller to remove the running command.

7. After T6, the inverter receives the stop command from the controller. With the delay of T7, the inverter stops output and withdraws the running signal. With the delay of T8, the inverter disconnects the contactor and the running process ends.

**Note:** The preceding logic is applicable to contactor and brake signal control by the inverter. For brake and contactor control signal output, the running signal can be used for contactor control and then the auxiliary point of the contactor and control system are serially connected for brake control.

The table below lists the typical function codes for multi-step speed running.

Function code	Name	Recommended value	Remarks
<a href="#">P00.00</a>	Speed control mode	1	SVC 1
<a href="#">P00.01</a>	Running command	1	Terminal control
<a href="#">P00.02</a>	Lift rated speed	1.500m/s	User defined
<a href="#">P00.03</a>	Speed command	3	Multi-step speed
<a href="#">P00.04</a>	Max. output frequency	50.00Hz	User defined
<a href="#">P01.01</a>	Starting frequency of direct startup	0.00 (closed-loop control) 0.50 (open-loop control)	
<a href="#">P01.12</a>	Stop knee-point frequency	1.00	Generally, the speed is consistent with the leveling speed. It is usually used to switch the stop curve. After the speed decreases to this point, the stop curves switches to the stop S curve.
<a href="#">P02.00</a>	Motor type	Determined motor type	According to the parameter values on the motor name plate
<a href="#">P02.01</a>	Motor rated power	Parameter value on the motor name plate	
<a href="#">P02.02</a>	Motor rated frequency	Parameter value on the motor name plate	
<a href="#">P02.03</a>	Motor rated rotation speed	Parameter value on the motor name plate	
<a href="#">P02.04</a>	Motor rated voltage	Parameter value on the motor name plate	
<a href="#">P02.05</a>	Motor rated current	Parameter value on the motor name plate	
<a href="#">P03 group</a>	Vector control	Default value	Adjusted based on the running conditions
<a href="#">P05.01</a>	S1 function selection	1	Upward running (FWD)

Function code	Name	Recommended value	Remarks
<a href="#">P05.02</a>	S2 function selection	2	Downward running (REV)
<a href="#">P05.03</a>	S3 function selection	19	Inverter enabling (ENA)
<a href="#">P05.04</a>	S4 function selection	8	Multi-step speed terminal 1 (MS1)
<a href="#">P05.05</a>	S5 function selection	9	Multi-step speed terminal 2 (MS2)
<a href="#">P05.06</a>	S6 function selection	10	Multi-step speed terminal 3 (MS3)
<a href="#">P05.07</a>	S7 function selection	17	Contactors feedback (TB)
<a href="#">P05.08</a>	S8 function selection	18	Brake feedback (FB)
<a href="#">P05.09</a>	S9 function selection	6	Fault reset (RET)
<a href="#">P05.12</a>	HDI terminal	3	Maintenance
<a href="#">P06.01</a>	Y output	1	Running feedback output
<a href="#">P06.04</a>	Relay 1 output	4	Fault output (EO)
<a href="#">P06.05</a>	Relay 2 output	7	Brake control (FC)
<a href="#">P06.06</a>	Relay 3 output	8	Contactors control (TC)
<a href="#">P08.04</a>	Brake close delay	0.1s	
<a href="#">P08.05</a>	Brake release delay	0.10s	
<a href="#">P08.06</a>	Brake feedback detection time	2.0	
<a href="#">P08.08</a>	Contactors feedback detection time	2.0	
<a href="#">P08.15</a>	Inverter stop delay	0.10s	
<a href="#">P09.00</a>	Multi-step speed 0	0 (Zero speed)	
<a href="#">P09.01</a>	Multi-step speed 1	Re-leveling speed	
<a href="#">P09.02</a>	Multi-step speed 2	Creeping speed	
<a href="#">P09.03</a>	Multi-step speed 3	Emergency speed	
<a href="#">P09.04</a>	Multi-step speed 4	Reserved	
<a href="#">P09.05</a>	Multi-step speed 5	Normally low speed	
<a href="#">P09.06</a>	Multi-step speed 6	Normally high speed 1	
<a href="#">P09.07</a>	Multi-step speed 7	Normally high speed 2	
<a href="#">P09.09</a>	S-curve ACC start segment duration	2.0s	Adjusted based on the onsite commissioning
<a href="#">P09.10</a>	S-curve ACC end segment duration	2.0s	

Function code	Name	Recommended value	Remarks
<a href="#">P09.11</a>	ACC time	2.0s	
<a href="#">P09.12</a>	S-curve DEC start segment duration	2.0s	
<a href="#">P09.13</a>	S-curve DEC end segment duration	2.0s	
<a href="#">P09.14</a>	DEC time	2.0s	
<a href="#">P09.15</a>	S-curve start segment duration during stop	2.0s	
<a href="#">P09.16</a>	S-curve end segment duration during stop	2.0s	
<a href="#">P09.17</a>	Maintenance running speed	0.200m/s	
<a href="#">P09.18</a>	Maintenance ACC/DEC time	4.0s	
<a href="#">P09.24</a>	DEC time for creeping to stop	2.0s	
<a href="#">P20.00</a>	Encoder type	Determined encoder type/pulse quantity	
<a href="#">P20.01</a>	Encoder pulse quantity		
<a href="#">P20.02</a>	Encoder direction	0	Modified according to the commissioning result

**Note:** In multi-step speed running mode, multi-step speed 0 must be set to zero speed.

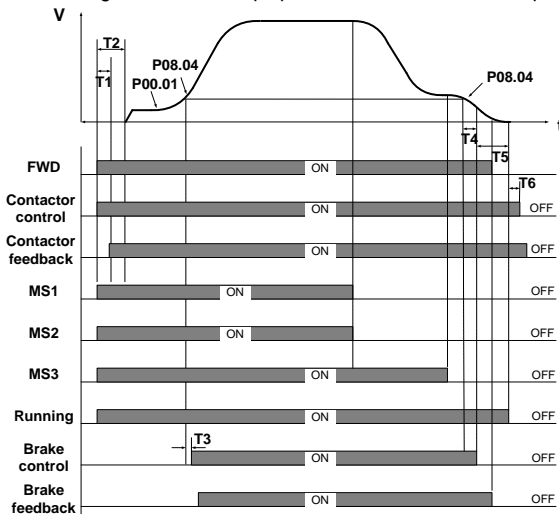

Figure 7-8 Open-loop running sequence

## Running sequence description:

1. After receiving the FWD and MS1–MS3 commands from the controller, the inverter sends the contactor close command and outputs the running signal.
2. With the delay of T2 after receiving the running command, the inverter starts to accelerate to the start frequency set in [P01.01](#).
3. After accelerating from the start frequency to the braking frequency ([P08.14](#)), the inverter sends the brake open signal with the delay of T3 ([P08.05](#), brake open delay).
4. After the brake is open, the inverter accelerates to the reference speed.
5. After the controller switches off the speed command (MS1–MS3), the inverter decelerates to stop according to the S curve. When the frequency reaches [P08.14](#) (stop braking frequency), the inverter outputs the brake close command with the delay of T4 ([P08.04](#), brake close delay), requiring the controller to remove the running command.
6. After receiving the stop command sent by the controller, the inverter stops output with the delay of T5 ([P08.15](#)), and the running signals are cancelled. After the delay of T6 ([P08.28](#)), the contactor is opened, and the running process ends.

The table below lists the typical function codes for open-loop running.

Function code	Name	Recommended value	Remarks
<a href="#">P00.00</a>	Speed control mode	0	SVC 0
<a href="#">P00.01</a>	Running command	1	Terminal
<a href="#">P00.02</a>	Lift rated speed	1.500m/s	User defined
<a href="#">P00.03</a>	Speed command	3	Multi-step speed running
<a href="#">P00.04</a>	Max. output frequency	50.00Hz	User defined
<a href="#">P01.00</a>	Start mode	1	Start after DC braking
<a href="#">P01.01</a>	Direct start frequency	0.2Hz	
<a href="#">P01.04</a>	Pre-start braking current	80%	
<a href="#">P01.08</a>	Start frequency in stop braking	0.2Hz	
<a href="#">P01.10</a>	Stop DC braking current	80%	
<a href="#">P01.12</a>	Stop knee-point frequency	5.00	Generally, the speed is consistent with the leveling speed. It is usually used to switch the stop curve. After the speed decreases to this point, the stop curves switches to the stop S curve.

Function code	Name	Recommended value	Remarks
<a href="#">P02.00</a>	Motor type	Determined motor type	According to the parameter values on the motor name plate
<a href="#">P02.01</a>	Motor rated power	Parameter value on the motor name plate	
<a href="#">P02.02</a>	Motor rated frequency	Parameter value on the motor name plate	
<a href="#">P02.03</a>	Motor rated rotation speed	Parameter value on the motor name plate	
<a href="#">P02.04</a>	Motor rated voltage	Parameter value on the motor name plate	
<a href="#">P02.05</a>	Motor rated current	Parameter value on the motor name plate	
<a href="#">P03 group</a>	Vector control	Default value	Adjusted based on the running conditions
<a href="#">P05.01</a>	S1 function selection	1	Upward running (FWD)
<a href="#">P05.02</a>	S2 function selection	2	Downward running (REV)
<a href="#">P05.03</a>	S3 function selection	19	Inverter enabling (ENA)
<a href="#">P05.04</a>	S4 function selection	8	Multi-step speed terminal 1 (MS1)
<a href="#">P05.05</a>	S5 function selection	9	Multi-step speed terminal 2 (MS2)
<a href="#">P05.06</a>	S6 function selection	10	Multi-step speed terminal 3 (MS3)
<a href="#">P05.07</a>	S7 function selection	17	Contactors feedback (TB)
<a href="#">P05.08</a>	S8 function selection	18	Brake feedback (FB)
<a href="#">P05.09</a>	S9 function selection	6	Fault reset (RET)

Function code	Name	Recommended value	Remarks
<a href="#">P05.12</a>	HDI terminal	3	Maintenance
<a href="#">P06.01</a>	Y output	1	Running feedback output
<a href="#">P06.04</a>	Relay 1 output	4	Fault output (EO)
<a href="#">P06.05</a>	Relay 2 output	7	Brake control (FC)
<a href="#">P06.06</a>	Relay 3 output	8	Contactors control (TC)
<a href="#">P08.04</a>	Brake close delay	0.1s	
<a href="#">P08.05</a>	Brake release delay	0.10s	
<a href="#">P08.06</a>	Brake feedback detection time	2.0	
<a href="#">P08.08</a>	Contactors feedback detection time	2.0	
<a href="#">P08.14</a>	Braking frequency	0.05Hz	
<a href="#">P08.15</a>	Inverter stop delay	0.10s	
<a href="#">P08.30</a>	Open-loop start brake open frequency of asynchronous motor	0.0 Hz	
<a href="#">P09.00</a>	Multi-step speed 0	0 (speed of zero)	Set based on user control requirements. The speed of step 0 is set to 0 m/s.
<a href="#">P09.01</a>	Multi-step speed 1	Leveling speed	
<a href="#">P09.02</a>	Multi-step speed 2	Emergency speed	
<a href="#">P09.03</a>	Multi-step speed 3	Common low speed	
<a href="#">P09.04</a>	Multi-step speed 4	Inspection speed	
<a href="#">P09.05</a>	Multi-step speed 5	Reserved	
<a href="#">P09.06</a>	Multi-step speed 6	Reserved	
<a href="#">P09.07</a>	Multi-step speed 7	Common high speed	
<a href="#">P09.09</a>	S-curve ACC start segment duration	2.0s	Adjusted based on onsite commissioning
<a href="#">P09.10</a>	S-curve ACC end segment duration	2.0s	
<a href="#">P09.11</a>	ACC time	2.0s	
<a href="#">P09.12</a>	S-curve DEC start segment duration	2.0s	
<a href="#">P09.13</a>	S-curve DEC end	2.0s	

Function code	Name	Recommended value	Remarks
	segment duration		
<a href="#">P09.14</a>	DEC time	2.0s	
<a href="#">P09.15</a>	S-curve start segment duration during stop	2.0s	
<a href="#">P09.16</a>	S-curve end segment duration during stop	2.0s	
<a href="#">P09.17</a>	Maintenance running speed	0.200m/s	
<a href="#">P09.18</a>	Maintenance ACC/DEC time	4.0s	
<a href="#">P09.24</a>	DEC time for creeping to stop	1.0s	

### 7.5.2 Analog tracking running

This running mode indicates that the speed command is provided by analog input, the inverter passively runs based on the analog signal as provided, the lift running curve is determined by the analog change curve generated by the external controller, and the inverter is responsible for driving the motor to run. The analog tracking running input channel must be provided by AI1 ([P00.03](#)=5).

#### Running sequence

The running sequence in this mode is similar to that in the multi-step speed running mode.

#### Note:

- During analog tracking running, the inverter internal S curve does not work, the S curve of lift running is generated by the lift controller. Adjusting [P05.17](#) or [P05.22](#) impacts the sensitivity of analog input.
- Great analog change ratio will cause inverter running frequency transient, which may result in inverter overcurrent or overvoltage.

### 7.5.3 Maintenance running

Figure 7-9 shows the basic wiring for maintenance running.

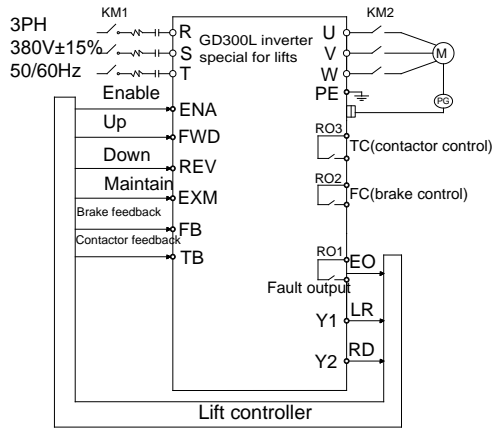

Figure 7-9 Wiring for maintenance running

The maintenance running is the same as the normal timing sequence. The maintenance ACC/DEC is linear. The maintenance speed is set by [P09.17](#).

Figure 7-10 shows the maintenance running timing sequence.

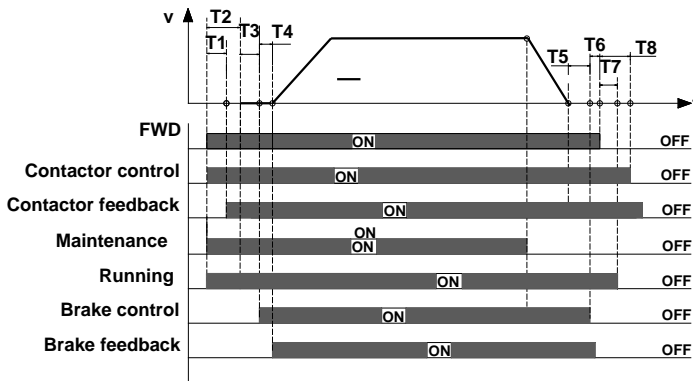

Figure 7-10 Maintenance running timing sequence

### 7.5.4 Emergency running

As shown in Figure 7-10, DC UPS connects to the inverter main circuit terminals (+) and (-) through KM3, D1 and D2 and connects to the control power board through contactor C, the control power board output connects to the inverter control power input terminals DC+ and DC-, and the main circuit power connects to the inverter main circuit terminals R, S, and T through KM1.

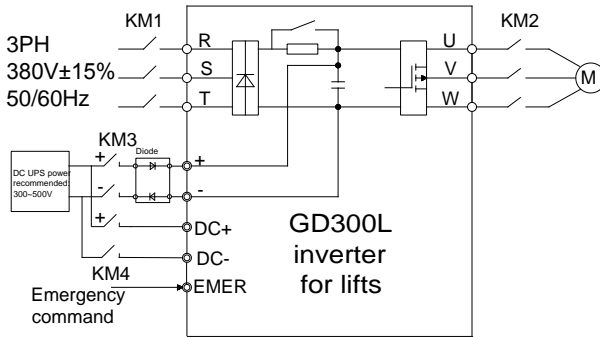

Figure 7-11 Wiring for emergency running

Emergency running terminals

Terminal	Description
EMER	Emergency running
FWD	Upward running
REV	Downward running
+, -	Inverter DC bus voltage wiring terminals
DC+, DC-	UPS emergency power wiring terminals
KM1	Control contactor of main power
KM3, KM4	Control contactors of emergency power

Emergency running timing sequence

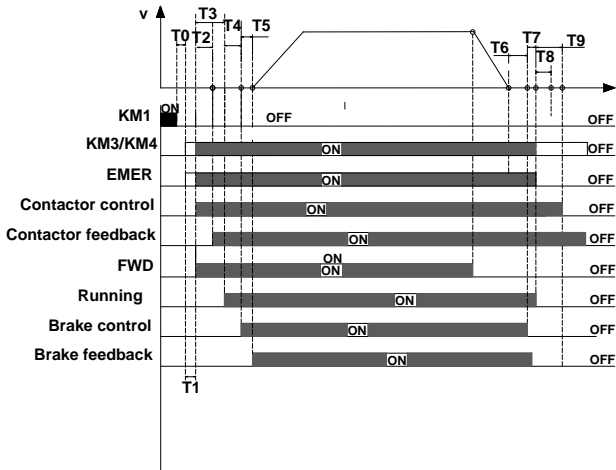

Figure 7-12 Emergency running timing sequence

The meanings of T0–T9 are as follows:

Symbol	Description
T0	Delay time from the main power is off to the switch of emergency power input contactors KM3 and KM4 are on
T1	Delay time from the time when the inverter receives the run signal to the time when the inverter outputs contactor actuation command
T2	Wait delay time from the time when the inverter outputs contactor actuation command to the time when the inverter receives the contactor feedback signal
T3	Relay time from the time when the run command is sent to the time when the run signal is output
T4	Delay time from the time when the run signal is output to the time when the brake open signal is sent.
T5	Interval from the brake open command sending time to the feedback time of brake open.
T6	<a href="#">P08.04</a> (Brake close delay time)
T7	Wait delay time from the time when the inverter outputs the brake close command to the time when the inverter receives the stop command from the external controller
T8	Inverter stop delay time
T9	<a href="#">P08.28</a> (Contactor switch-off delay)

After the main circuit power is off, contactor B is switched off first. Before the bus voltage decreases to 300V, contactor A and contactor C are switched on.

- When the main power is off, the controller cuts off main power relay (KM1), after T0, the control switch of emergency power will be closed, and output emergency command at the same time , after T1, the inverter receives the running command (FWD/REW) from the controller.
- Then after T2, the inverter detects the contactor actuation command signal, and then the inverter starts to run at zero speed, at the same time outputs running signal (Y1). After T4, the inverter outputs brake release signal.
- After T5, the inverter receives brake feedback signal, after affirming the brake is released completely, the inverter accelerates with emergency acceleration time ([P09.21](#)) to reach to emergency speed ([P09.20](#)), and then runs at a constant speed.
- When the lift runs to the flat floor, the controller will cut off emergency command (EMER), and the inverter begins to decelerate to stop with emergency deceleration ([P09.21](#)), when the inverter decelerates to [P08.14](#), after T6, the inverter outputs brake close command, and requires the controller to cut off running command.
- After T7, the inverter receives stop command, and then after the delay time of T8 and T9, the

inverter stops, and outputs contactor releasing command and lift stop signal (Y1). By now, one operation cycle ends.

### 7.5.5 Distance control

Function code	Name	Recommended value	Remarks
<a href="#">P02.14</a>	Pulley diameter	100 - 2000mm	500mm
<a href="#">P02.15</a>	DEC ratio	0.50 - 50.00	1.00
<a href="#">P21.00</a>	control	0x00 - 0x11 Ones place: Enable control over the distance between high-speed running and creeping 0: Disabled; 1: Enabled Tens place: Enable control over the distance between creeping and stop 0: Disabled; 1: Enabled	0
<a href="#">P21.01</a>	High-speed running DEC distance	0.200-3.000m	1.800
<a href="#">P21.02</a>	Medium- and low-speed DEC distance	0.100-3.000m	1.000
<a href="#">P21.03</a>	DEC distance for creeping to stop	0.010-1.000m	0.080
<a href="#">P21.04</a>	UP DEC adjustment distance	-0.300 - 0.300m	0.000
<a href="#">P21.05</a>	Down DEC adjustment distance	-0.300 - 0.300m	0.000
<a href="#">P21.06</a>	High-speed step of multi-step speed running	0 - 7	3
<a href="#">P21.07</a>	Medium- and low-speed step of multi-step speed running	0 - 7	1
<a href="#">P21.08</a>	Creeping step of multi-step speed running	0 - 7	0

When distance control [P21.00](#) is set to 0x11, the distance for decelerating from high speed to 0 is [P21.01](#), and that for decelerating from medium or low speed to 0 is [P21.02](#), as shown in Figure 7-13.

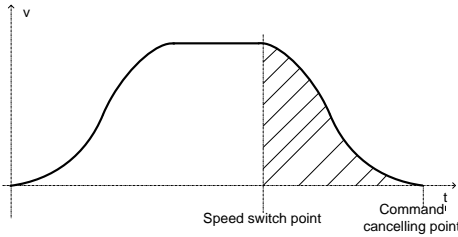

Figure 7-13 Curve of deceleration without creeping

When distance control [P21.00](#) is set to 0x11, the distance for decelerating from high speed to creeping speed is [P21.01](#), that for decelerating from medium or lower speed to creeping speed is [P21.02](#), and that for decelerating from creeping speed to 0 is [P21.03](#), as shown in Figure 7-14.

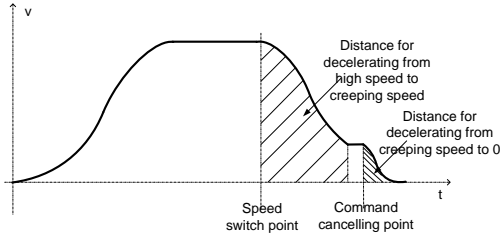



Figure 7-14 Curve of deceleration with creeping

## 8 Fault tracking

### 8.1 What this chapter contains

This chapter tells how to reset faults and view fault history. It also lists all alarm and fault messages including the possible cause and corrective actions.

	⇨ Only qualified electricians are allowed to maintain the inverter. Read the safety instructions in chapter <b>Safety precautions</b> before working on the inverter.
---	---

### 8.2 Alarm and fault indications

Fault is indicated by LEDs. See **Keypad operation Procedure**. When **TRIP** light is on, an alarm or fault message on the panel display indicates abnormal inverter state. Using the information given in this chapter, most alarm and fault cause can be identified and corrected. If not, contact with the INVT office.

### 8.3 How to reset

The inverter can be reset by pressing the keypad key **STOP/RST**, through digital input, or by switching the power light. When the fault has been removed, the motor can be restarted.

### 8.4 Fault history

Function codes [P07.28–P07.37](#) store 10 recent faults. Function codes [P07.38–P07.45](#), [P07.46–P07.54](#), and [P07.55–P07.61](#) show inverter operation data at the time the latest 3 faults occurred.

### 8.5 Inverter faults and solutions

Do as the following after the inverter fault:

1. Check to ensure there is nothing wrong with the keypad. If not, please contact with the local INVT office.
2. If there is nothing wrong, please check [P07](#) and ensure the corresponding recorded fault parameters to confirm the real state when the current fault occurs by all parameters.
3. See the following table for detailed solution and check the corresponding abnormal state.
4. Eliminate the fault and ask for relative help.
5. Check to eliminate the fault and carry out fault reset to run the inverter.

#### 8.5.1 Inverter faults and solutions

Code	Fault	Possible cause	Solution
OUt1	IGBT U phase protection	●The acceleration is too fast	●Increase ACC time ●Change the power unit
OUt2	IGBT V phase protection	●There is damage to the internal to IGBT of the phase	●Check the driving wires ●Check if there is strong interference to the external equipment
OUt3	IGBT W phase	●The connection of the	

Code	Fault	Possible cause	Solution
	protection	driving wires is not good <ul style="list-style-type: none"> <li>● The grounding is not good; Interference causes maloperation</li> </ul>	
OV1	ACC overvoltage	<ul style="list-style-type: none"> <li>●The input voltage is abnormal</li> <li>●There is large energy feedback</li> <li>●No braking components</li> <li>●Braking energy is not open</li> </ul>	<ul style="list-style-type: none"> <li>●Check the input power</li> <li>●Check if the DEC time of the load is too short or the inverter starts during the rotation of the motor or it needs to increase the energy consumption components</li> <li>●Install the braking components</li> <li>●Check the setting of relative function codes</li> </ul>
OV2	DEC overvoltage		
OV3	Constant overvoltage		
OC1	ACC overcurrent	<ul style="list-style-type: none"> <li>●The acceleration or deceleration is too fast</li> <li>●The voltage of the grid is too low</li> <li>●The power of the inverter is too low</li> <li>●The load transients or is abnormal</li> <li>●The grounding is short circuited or the output is phase loss</li> <li>●There is strong external interference</li> <li>●The overvoltage stall protection is not open</li> </ul>	<ul style="list-style-type: none"> <li>●Increase the ACC time</li> <li>●Check the input power</li> <li>●Select the inverter with a larger power</li> <li>●Check if the load is short circuited (the grounding short circuited or the wire short circuited) or the rotation is not smooth</li> <li>●Check the output configuration.</li> <li>●Check if there is strong interference</li> <li>●Check the setting of relative function codes</li> </ul>
OC2	DEC overcurrent		
OC3	Constant overcurrent		
UV	Bus undervoltage fault	<ul style="list-style-type: none"> <li>●The voltage of the power supply is too low</li> <li>●The overvoltage stall protection is not open</li> </ul>	<ul style="list-style-type: none"> <li>●Check the input power of the supply line</li> <li>●Check the setting of relative function codes</li> </ul>
OL1	Motor overload	<ul style="list-style-type: none"> <li>●The voltage of the power supply is too low</li> <li>●Motor rated current is incorrect</li> <li>●The motor stall or load</li> </ul>	<ul style="list-style-type: none"> <li>●Check the power of the supply line</li> <li>●Reset the rated current of the motor</li> <li>●Check the load and adjust</li> </ul>

Code	Fault	Possible cause	Solution
		transients is too strong	the torque lift
OL2	Inverter overload	<ul style="list-style-type: none"> <li>●The acceleration is too fast</li> <li>●Reset the rotating motor</li> <li>●The voltage of the power supply is too low.</li> <li>●The load is too heavy.</li> <li>●Close loop vector control, reverse direction of the code panel and long low-speed operation</li> </ul>	<ul style="list-style-type: none"> <li>●Increase the ACC time</li> <li>●Avoid the restarting after stopping.</li> <li>●Check the power of the supply line</li> <li>●Select an inverter with bigger power.</li> <li>●Select a proper motor.</li> </ul>
SPI	Input phase loss	Phase loss or fluctuation of input R,S,T	<ul style="list-style-type: none"> <li>●Check input power</li> <li>●Check installation distribution</li> </ul>
SPO	Output phase loss	U,V,W phase loss input(or serious asymmetrical three phase of the load)	<ul style="list-style-type: none"> <li>●Check the output distribution</li> <li>●Check the motor and cable</li> </ul>
OH1	Rectifying module overheated	<ul style="list-style-type: none"> <li>●Air duct jam or fan damage</li> </ul>	<ul style="list-style-type: none"> <li>●Redistribute dredge the wind channel or change the fan</li> <li>●Low the ambient temperature</li> </ul>
OH2	IGBT overheated	<ul style="list-style-type: none"> <li>●Ambient temperature is too high.</li> <li>●The time of overload running is too long.</li> </ul>	
EF	External fault	SI external fault input terminals action	Check the external device input
CE	485 communication fault	<ul style="list-style-type: none"> <li>●The baud rate setting is incorrect.</li> <li>●Fault occurs to the communication wiring.</li> <li>●The communication address is wrong.</li> <li>●There is strong interference to the communication.</li> </ul>	<ul style="list-style-type: none"> <li>●Set proper baud rate</li> <li>●Check the communication connection distribution</li> <li>●Set proper communication address.</li> <li>●Change or replace the connection distribution or improve the anti-interference capability.</li> </ul>
ItE	Current-detecting fault	<ul style="list-style-type: none"> <li>●The connection of the control board is not good</li> <li>●Hoare component is</li> </ul>	<ul style="list-style-type: none"> <li>●Check the connector and repatch</li> <li>●Change the Hoare</li> </ul>

Code	Fault	Possible cause	Solution
		broken ●The amplifying circuit is abnormal.	●Change the main control panel
tE	Motor-autotuning fault	●The motor capacity does not comply with the inverter capability ●The rated parameter of the motor does not set correctly. ●The offset between the parameters from autotune and the standard parameter is huge ●Autotune overtime	●Change the inverter mode ●Set the rated parameter according to the motor name plate ●Empty the motor load and reidentify ●Check the motor connection and set the parameter. ●Check if the upper limit frequency is above 2/3 of the rated frequency.
EEP	EEPROM operation fault	●Error of controlling the write and read of the parameters ●Damage to EEPROM	●Press STOP/RST to reset ●Change the main control panel
PIDE	PID feedback outline fault	●PID feedback offline ●PID feedback source disappear	●Check the PID feedback signal ●Check the PID feedback source
bCE	Brake unit fault	●Braking circuit fault or damage to the braking pipes ●The external brake resistor is not sufficient	●Check the brake unit and , change new braking pipe ●Increase the brake resistor
END	Running time arrival	The actual running time of the inverter is above the internal setting running time.	Ask for the supplier and adjust the setting running time.
OL3	Electrical overload	The inverter will report overload alarm according to the set value.	Check the load and the overload pre-alarm point.
PCE	Keypad communication fault	●The connection of the keypad wires is not good or broken.	●Check the keypad wires and ensure whether there is mistake.

Code	Fault	Possible cause	Solution
		<ul style="list-style-type: none"> <li>●The keypad wire is too long and affected by strong interference.</li> <li>●There is circuit fault on the communication of the keypad and main board.</li> </ul>	<ul style="list-style-type: none"> <li>●Check the environment and avoid the interference source.</li> <li>●Change the hardware and ask for service.</li> </ul>
UPE	Parameters uploading fault	<ul style="list-style-type: none"> <li>●The connection of the keypad wires is not good or broken.</li> <li>●The keypad wire is too long and affected by strong interference.</li> <li>●Communication fault.</li> </ul>	<ul style="list-style-type: none"> <li>●Check the keypad wires and ensure whether there is mistake.</li> <li>●Change the hardware and ask for service.</li> <li>●Change the hardware and ask for service.</li> </ul>
DNE	Parameters downloading fault	<ul style="list-style-type: none"> <li>●The connection of the keypad wires is not good or broken.</li> <li>●The keypad wire is too long and affected by strong interference.</li> <li>●There is mistake on the data storage of the keypad.</li> </ul>	<ul style="list-style-type: none"> <li>●Check the keypad wires and ensure whether there is mistake.</li> <li>●Change the hardware and ask for service.</li> <li>●Repack-up the data in the keypad.</li> </ul>
E-DP	PROFIBUS communication fault	<ul style="list-style-type: none"> <li>●Communication address is not correct.</li> <li>●Corresponding resistor is not dialed</li> <li>●The files of main stop GSD does not set sound</li> </ul>	Check related setting
E-NET	Ethernet communication fault	<ul style="list-style-type: none"> <li>●The Ethernet address is not set right.</li> <li>●The Ethernet communication is not selected to right.</li> <li>●The ambient interference is too strong.</li> </ul>	<ul style="list-style-type: none"> <li>●Check the relative setting.</li> <li>Check the communication method selection.</li> <li>●Check the environment and avoid the interference.</li> </ul>
E-CAN	CANopen communication fault	<ul style="list-style-type: none"> <li>●The connection is not sound</li> </ul>	<ul style="list-style-type: none"> <li>●Check the connection</li> <li>●Draw out the correspond</li> </ul>

Code	Fault	Possible cause	Solution
		<ul style="list-style-type: none"> <li>●Corresponding resistor is not dialed</li> <li>●The communication is uneven</li> </ul>	resistor <ul style="list-style-type: none"> <li>●Set the same baud rate</li> </ul>
ETH1	Grounding shortcircuit fault 1	<ul style="list-style-type: none"> <li>●The output of the inverter is short circuited with the ground.</li> <li>●There is fault in the current detection circuit.</li> </ul>	<ul style="list-style-type: none"> <li>●Check if the connection of the motor is normal or not</li> <li>●Change the Hoare</li> <li>●Change the main control panel</li> </ul>
ETH2	Grounding shortcircuit fault 2	<ul style="list-style-type: none"> <li>●The output of the inverter is short circuited with the ground.</li> <li>●There is fault in the current detection circuit.</li> </ul>	<ul style="list-style-type: none"> <li>●Check if the connection of the motor is normal or not</li> <li>●Change the Hoare</li> <li>Change the main control panel</li> </ul>
dEu	Speed deviation fault	The load is too heavy or stalled.	<ul style="list-style-type: none"> <li>●Check the load and ensure it is normal. Increase the detection time.</li> <li>●Check whether the control parameters are normal.</li> </ul>
STo	Maladjustment fault	<ul style="list-style-type: none"> <li>●The control parameters of the synchronous motors not set properly.</li> <li>●The autotune parameter is not right.</li> <li>●The inverter is not connected to the motor.</li> </ul>	<ul style="list-style-type: none"> <li>●Check the load and ensure it is normal.</li> <li>●Check whether the control parameter is set properly or not.</li> <li>●Increase the maladjustment detection time.</li> </ul>
LL	Electronic underload fault	The inverter will report the underload pre-alarm according to the set value.	Check the load and the underload pre-alarm point.
ENC10	Encoder disconnection fault	<ul style="list-style-type: none"> <li>●Incorrect encoder wiring, causes the failure to get the encoder signal.</li> <li>●Incorrect encoder parameter settings</li> </ul>	<ul style="list-style-type: none"> <li>●Check the wiring.</li> <li>●Check encoder parameter settings.</li> </ul>

Code	Fault	Possible cause	Solution
ENC1D	Encoder reserve-rotation fault	Incorrect encoder signal direction	Set the function code to change the direction or reverse the AB signal wires.
ENC1Z	Encoder Z-pulse disconnection fault	The Z-pulse signal cable is not connected.	Check the Z-pulse signal cable.
ENC1U	U disconnection	There are no U, V, or W signals or there is interference.	Check the U, V, and W signal wiring.
OT	Motor overtemperature fault	Motor overtemperature signal	
BAE	Brake fault	<ul style="list-style-type: none"> <li>● Brake signal and control signal are inconsistent</li> <li>● Feedback terminal signal is interfered.</li> </ul>	<ul style="list-style-type: none"> <li>● Check whether the brake is in good condition.</li> <li>● Check feedback terminal signal.</li> </ul>
CONE	Contactor fault	<ul style="list-style-type: none"> <li>● Brake feedback and control signal are inconsistent.</li> <li>● Feedback terminal signal is interfered.</li> </ul>	<ul style="list-style-type: none"> <li>● Check whether the contactor is in good condition.</li> <li>● Check feedback terminal signal.</li> </ul>
nPoS	CD signal unavailable	<ul style="list-style-type: none"> <li>● The sine-cosine or absolute-value encoder position signal is lost.</li> <li>● The encoder is interfered.</li> </ul>	<ul style="list-style-type: none"> <li>● Check whether the encoder is in good condition.</li> <li>● Check whether the inverter and encoder are grounded.</li> </ul>
SAFE	STO card fault	<ul style="list-style-type: none"> <li>● The STO card safety circuit does not work.</li> <li>● The expansion card type is incorrect.</li> </ul>	<ul style="list-style-type: none"> <li>● Check whether the STO card is in good condition.</li> <li>● Check whether the expansion card type is correct.</li> </ul>
STL1	STO card circuit 1 exception	Circuit 1 of the STO card does not work.	<ul style="list-style-type: none"> <li>● Check whether the STO card is in good condition.</li> <li>● Check circuit 1 of the STO card.</li> </ul>
STL2	STO card circuit 2 exception	Circuit 2 of the STO card does not work.	<ul style="list-style-type: none"> <li>● Check whether the STO card is in good condition.</li> </ul>

Code	Fault	Possible cause	Solution
			●Check circuit 2 of the STO card.
STL3	STO internal circuit exception	The internal circuits of the STO card do not work.	Check whether the circuits of the inverter control board is in good condition.
CrCE	Safety code CRC exception	Exceptions occur in the verification of the safety circuit code.	Check whether the control board is in good condition.

8.5.2 Other faults

Code	Fault	Possible cause	Solution
PoFF	Power off	The system is powered off or bus voltage is too low.	Check the grid environment.
	Keypad and main control panel communication failure	Improper keypad connection.	Check the keypad installation environment.

8.6 Common fault analysis

8.6.1 The motor does not work

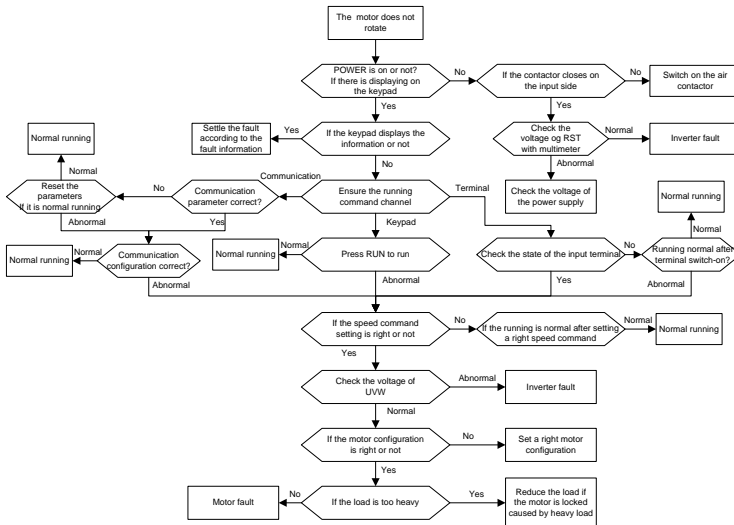

8.6.2 Motor vibration

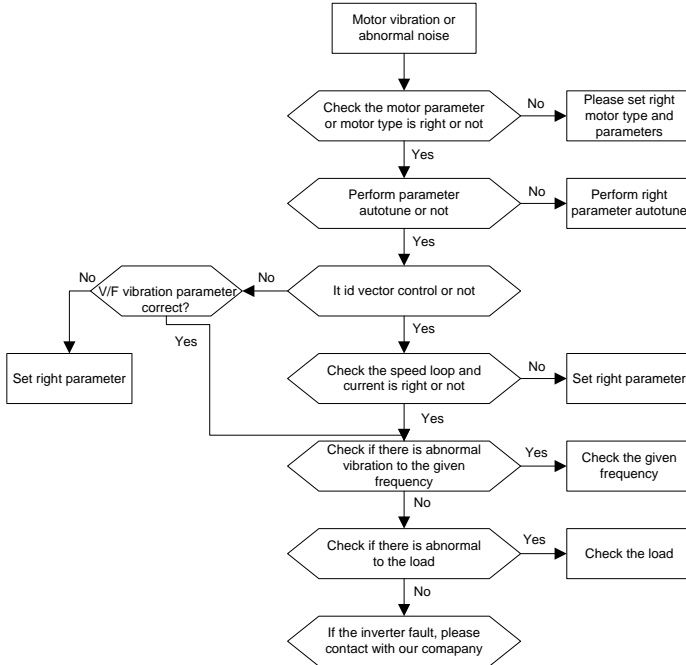

8.6.3 Overvoltage

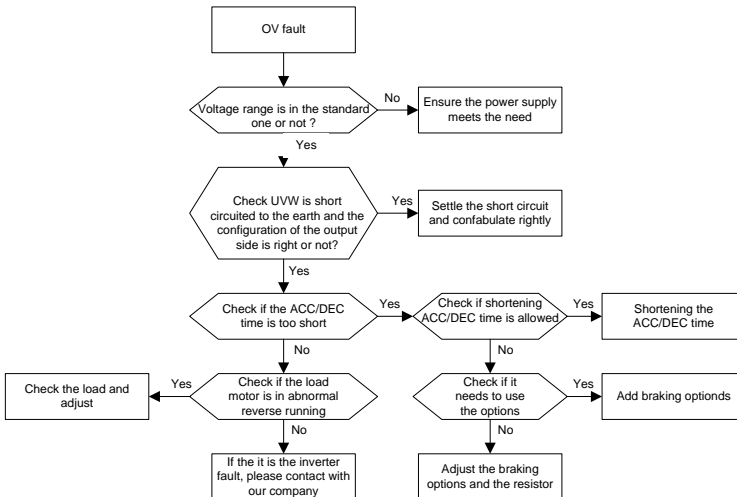

### 8.6.4 Undervoltage fault

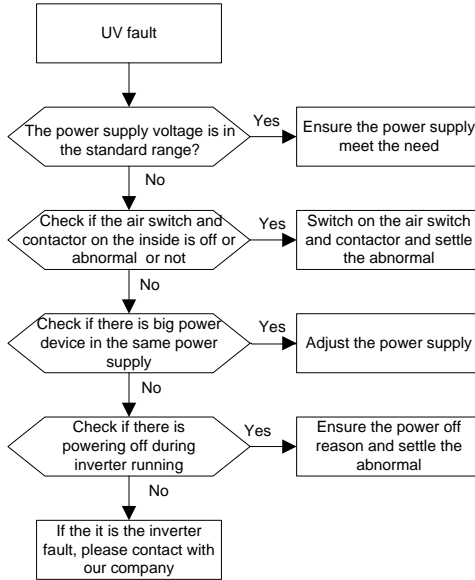

8.6.5 Abnormal heating of the motor

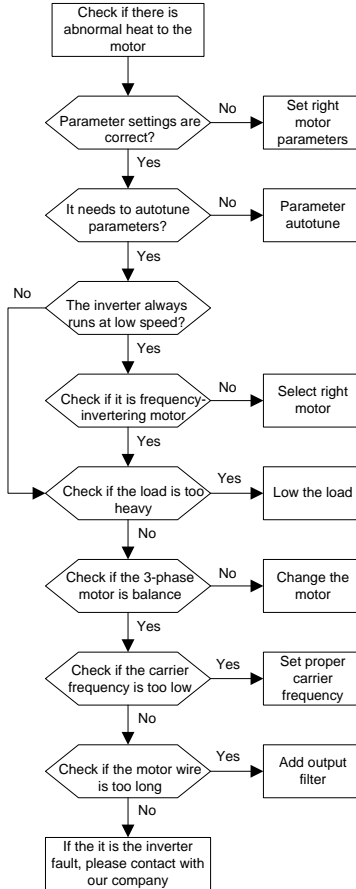

### 8.6.6 Overheat of the inverter

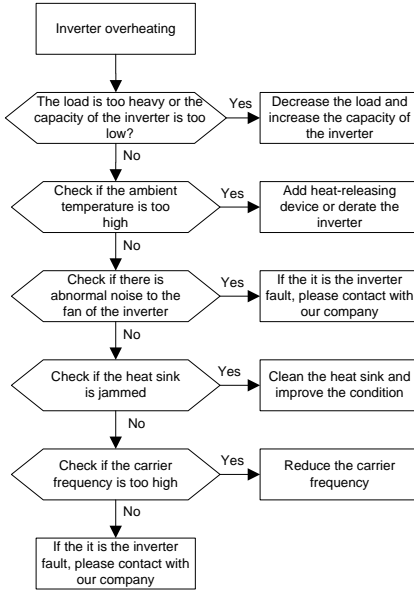

### 8.6.7 Motor stall during ACC

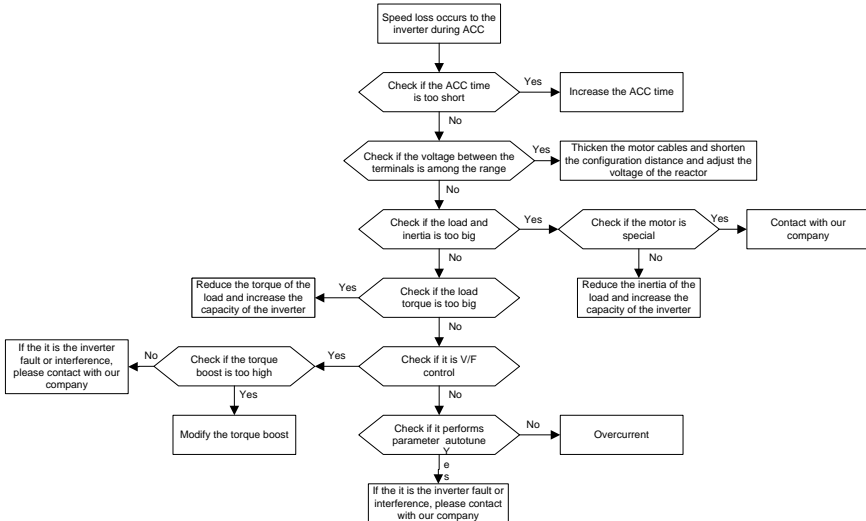

8.6.8 Overcurrent

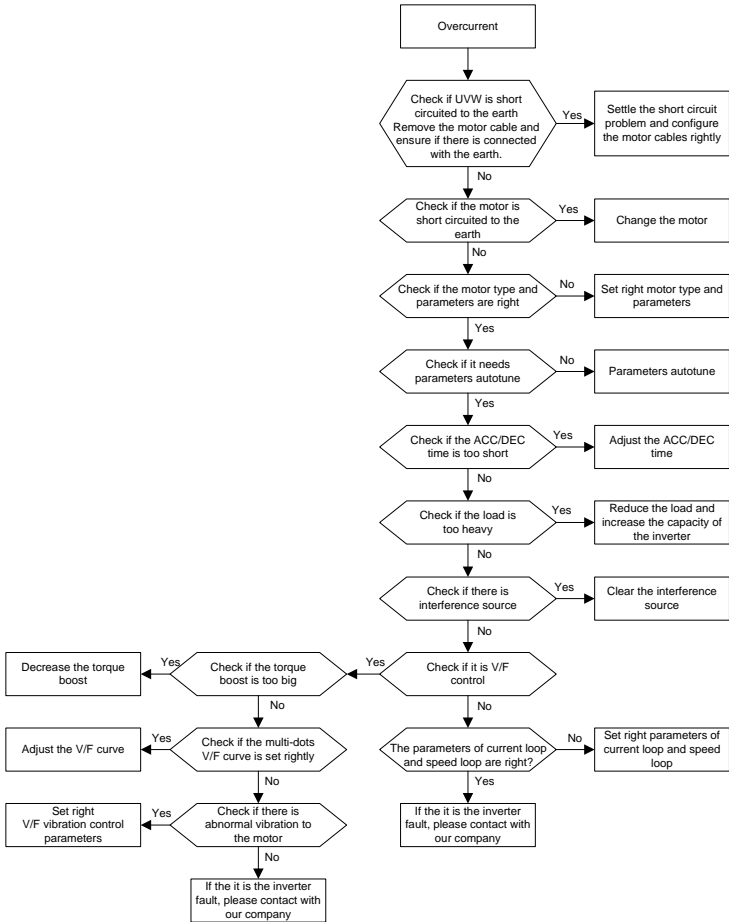

## 9 Maintenance and hardware diagnosis

### 9.1 What this chapter contains

The chapter contains preventive maintenance instructions of the inverter.

### 9.2 Maintenance intervals

If installed in an appropriate environment, the inverter requires very little maintenance. The table lists the routine maintenance intervals recommended by INVT.

Checking		Item	Method	Criterion
Ambient environment		Check the ambient temperature, humidity and vibration and ensure there is no dust, gas, oil fog and water drop.	Visual examination and instrument test	Conforming to the manual
		Ensure there are no tools or other foreign or dangerous objects	Visual examination	There are no tools or dangerous objects.
Voltage		Ensure the main circuit and control circuit are normal.	Measurement by millimeter	Conforming to the manual
Keypad		Ensure the display is clear enough	Visual examination	The characters are displayed normally.
		Ensure the characters are displayed totally	Visual examination	Conforming to the manual
Main circuit	For public use	Ensure the screws are tightened securely	Tighten up	NA
		Ensure there is no distortion, crackles, damage or color change caused by overheat or aging to the machine and insulator.	Visual examination	NA
		Ensure there is no dust and dirtiness	Visual examination	NA Copper block color change does not mean feature problem.
	Conductor	Ensure that there is no	Visual examination	NA

Checking		Item	Method	Criterion
	lead	distortion or color-changing of the conductors caused by overheating.		
		Ensure that there are no crackles or color-changing of the protective layers.	Visual examination	NA
	Terminal seat	Ensure that there is no damage	Visual examination	NA
	Filter capacitors	Ensure that there is no weeping, color-changing, crackles and cassis expansion.	Visual examination	NA
		Ensure the safety valve is in the right place.	Estimate the usage time according to the maintenance or measure the static capacity.	NA
		If necessary, measure the static capacity.	Measure the capacity by instruments.	The static capacity is above or equal to the original value *0.85.
	Resistors	Ensure whether there is replacement and splitting caused by overheating.	Smelling and visual examination	NA
		Ensure that there is no offline.	Visual examination or remove one ending to coagulate or measure with multimeters	The resistors are in $\pm 10\%$ of the standard value.
	Transformers and reactors	Ensure there is no abnormal vibration, noise and smelling,	Hearing, smelling and visual examination	NA
	Electromagnetic	Ensure there is no vibration or noise in the workrooms.	Hearing	NA

Checking		Item	Method	Criterion
	contactors and relays	Ensure the contactor is in good contact.	Visual examination	NA
Control circuit	PCB and plugs	Ensure there are no loose screws and contactors.	Fasten up	NA
		Ensure there is no smelling and color-changing.	Smelling and visual examination	NA
		Ensure there are no crackles, damage distortion and rust.	Visual examination	NA
		Ensure there is no weeping and distortion to the capacitors.	Visual examination or estimate the usage time according to maintenance information	NA
Cooling system	Cooling fan	Ensure there is no abnormal noise and vibration.	Hearing and visual examination or rotate with hand	Stable rotation
		Estimate there is no losses screw.	Tighten up	NA
		Ensure there is no color-changing caused by overheating.	Visual examination or estimate the usage time according to maintenance information	NA
	Ventilating duct	Ensure there is no stuff or foreign objection in the cooling fan, air vent.	Visual examination	NA

Consult the local service representative for more details on the maintenance. Visit the official website <http://www.invt.com.cn>.

### 9.3 Cooling fan

The inverter's cooling fan has a minimum life span of 25,000 operating hours. The actual life span depends on the inverter usage and ambient temperature.

The operating hours can be found through [P07.13](#).

Fan failure can be predicted by the increasing noise from the fan bearings. If the inverter is operated

in a critical part of a process, fan replacement is recommended once these symptoms appear. Spare fans are also available.

### 9.3.1 Replacing the cooling fan



⇨ Read and follow the instructions in chapter **Safety precautions**. Ignoring the instructions would cause physical injury or death, or damage to the equipment.

1. Stop the inverter and disconnect it from the AC power source and wait for at least the time designated on the inverter.
2. Loosen the fan cable from the clip.
3. Disconnect the fan cable.
4. Remove the fan.
5. Install the new fan in the inverter, put the fan cables in the clip and then fix the inverter well.
6. Connect the power supply.

## 9.4 Capacitors

### 9.4.1 Capacitors reforming

The DC bus capacitors must be reformed according to the operation instruction if the inverter has been stored for a long time. The storing time is counted from the producing date other than the delivery data which has been marked in the serial number of the inverter.

Time	Operational principle
Storing time less than 1 year	Operation without charging
Storing time 1-2 years	Connect with the power for 1 hour before first ON command
Storing time 2-3 years	Use power surge to charge for the inverter <ul style="list-style-type: none"> <li>• charging 25% rated voltage for 30 minutes</li> <li>• charging 50% rated voltage for 30 minutes</li> <li>• charging 75% rated voltage for 30 minutes</li> <li>• charging 100% rated voltage for 30 minutes</li> </ul>
Storing time more than 3 years	Use power surge to charge for the inverter <ul style="list-style-type: none"> <li>• charging 25% rated voltage for 2 hours</li> <li>• charging 50% rated voltage for 2 hours</li> <li>• charging 75% rated voltage for 2 hours</li> <li>• charging 100% rated voltage for 2 hours</li> </ul>

Use voltage-adjusting power supply to charge the inverter:

The right selection of the voltage-adjusting power supply depends on the supply power of the inverter. Single phase 220V AC/2A power surge is applied to the inverter of single/three-phase 220V AC. The inverter of single/three-phase 220V AC can apply single phase 220V AC/2A power surge (L+ to R; N

to S or T). All DC bus capacitors can charge at the same time because there is one rectifier.

High-voltage inverter needs enough voltage (for example, 380V) during charging. The small capacitor power (2A is enough) can be used because the capacitor nearly does not need current when charging.

The operation method of inverter charging through resistors (LEDs):

The charging time is at least 60 minutes if charge the DC bus capacitor directly through supply power. This operation is available on normal temperature and no-load condition and the resistor should be serially connected in the 3-phase circuits of the power supply:

- a) 380V drive device: 1k/100W resistor. LED of 100W can be used when the power voltage is no more than 380V. But if used, the light may be off or weak during charging.
- b) 500V drive device: 1k/140W resistor
- c) 660V drive device: 1k/160W resistor

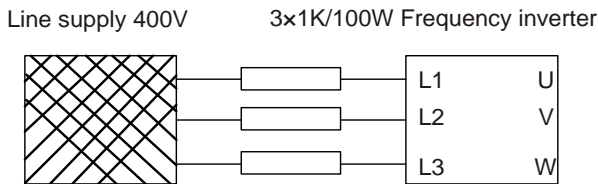

Figure 9-1 380V charging illustration of the driven device

#### 9.4.2 Change electrolytic capacitors



◇ Read and follow the instructions in chapter *Safety Precautions*. Ignoring the instructions may cause physical injury or death, or damage to the equipment.

Change electrolytic capacitors if the working hours of electrolytic capacitors in the inverter are above 35000. Please contact with the local offices or dial our national service hotline (400-700-9997) for detailed operation.

#### 9.5 Power cable



◇ Read and follow the instructions in chapter *Safety Precautions*. Ignoring the instructions may cause physical injury or death, or damage to the equipment.

1. Stop the drive and disconnect it from the power line. Wait for at least the time designated on the inverter.
2. Check the tightness of the power cable connections.
3. Restore power.

## 10 Communication protocol

### 10.1 What this chapter contains

This chapter describes the communication protocol of GD300L series inverters special for lifts.

GD300L series inverters special for lifts support IO expansion cards and provide RS485 communication interface. It adopts international standard ModBus communication protocol to perform master-slave communication. The user can realize centralized control through PC/PLC, upper control PC, etc. (set the control command, running frequency of the inverter, modify relevant function codes, monitor and control the operating state and fault information of the inverter and so on) to adapt specific application requirements.

### 10.2 Brief instruction to Modbus protocol

Modbus protocol is a software protocol and common language which is applied in the electrical controller. With this protocol, the controller can communicate with other devices via network (the channel of signal transmission or the physical layer, such as RS485). And with this industrial standard, the controlling devices of different manufacturers can be connected to an industrial network for the convenient of being monitored.

There are two transmission modes for Modbus protocol: ASCII mode and RTU (Remote Terminal Units) mode. On one Modbus network, all devices should select same transmission mode and their basic parameters, such as baud rate, digital bit, check bit, and stopping bit should have no difference.

Modbus network is a controlling network with single-master and multiple slaves, which means that there is only one device performs as the master and the others are the slaves on one Modbus network. The master means the device which has active talking right to send message to Modbus network for the controlling and inquiring to other devices. The slave means the passive device which sends data message to the Modbus network only after receiving the controlling or inquiring message (command) from the master (response). After the master sends message, there is a period of time left for the controlled or inquired slaves to response, which ensure there is only one slave sends message to the master at a time for the avoidance of singles impact.

Generally, the user can set PC, PLC, IPC and HMI as the masters to realize central control. Setting certain device as the master is a promise other than setting by a bottom or a switch or the device has a special message format. For example, when the upper monitor is running, if the operator clicks sending command bottom, the upper monitor can send command message actively even it cannot receive the message from other devices. In this case, the upper monitor is the master. And if the designer makes the inverter send the data only after receiving the command, then the inverter is the slave.

The master can communicate with any single slave or with all slaves. For the single-visiting command, the slave should feedback a response message; for the broadcasting message from the master, the slave does not need to feedback the response message.

### 10.3 Application of the inverter

The Modbus protocol of the inverter is RTU mode and the physical layer is RS485.

#### 10.3.1 RS485

The interface of RS485 works on semiduplex and its data signal applies differential transmission which is called balance transmission, too. It uses twisted pairs, one of which is defined as A (+) and the other is defined as B (-). Generally, if the positive electrical level between sending drive A and B is among +2—+6V, it is logic "1", if the electrical level is among -2V—-6V, it is logic "0".

485+ on the terminal board corresponds to A and 485- to B.

Communication baud rate means the binary bit number in one second. The unit is bit/s (bps). The higher the baud rate is, the quicker the transmission speed is and the weaker the anti-interference is. If the twisted pairs of 0.56mm (24AWG) is applied as the communication cables, the Max. Transmission distance is as below:

Baud rate	Max. transmission distance	Baud rate	Max. transmission distance
2400BPS	1800m	9600BPS	800m
4800BPS	1200m	19200BPS	600m

It is recommended to use shield cables and make the shield layer as the grounding wires during RS485 remote communication.

In the cases with less devices and shorter distance, it is recommended to use 120Ω terminal resistor as the performance will be weakened if the distance increase even though the network can perform well without load resistor.

#### 10.3.2.1 Single application

Figure 10-1 is the site Modbus connection figure of single inverter and PC. Generally, the computer does not have RS485 interface, the RS232 or USB interface of the computer should be converted into RS485 by converter. Connect the A terminal of RS485 to the 485+ terminal of the inverter and B to the 485- terminal. It is recommended to use the shield twisted pairs. When applying RS232-RS485 converter, if the RS232 interface of the computer is connected to the RS232 interface of the converter, the wire length should be as short as possible within the length of 15m. It is recommended to connect the RS232-RS485 converter to the computer directly. If using USB-RS485 converter, the wire should be as short as possible, too.

Select a right interface to the upper monitor of the computer (select the interface of RS232-RS485 converter, such as COM1) after the wiring and set the basic parameters such as communication baud rate and digital check bit to the same as the inverter.

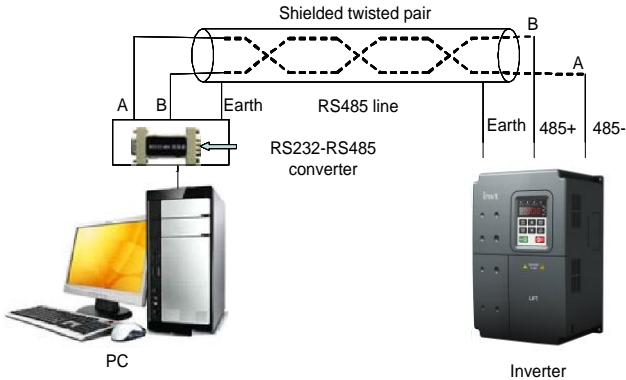

Figure 10-1 RS485 physical connection in single application

10.3.1.2 Multi-application

In the real multi-application, the chrysanthemum connection and star connection are commonly used. Chrysanthemum chain connection is required in the RS485 industrial fieldbus standards. The two ends are connected to terminal resistors of 120Ω which is shown as Figure 10-2. Figure 10-3 is the simply connection figure and Figure 10-4 is the real application figure.

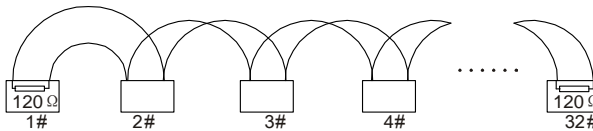

Figure 10-2 Chrysanthemum connection

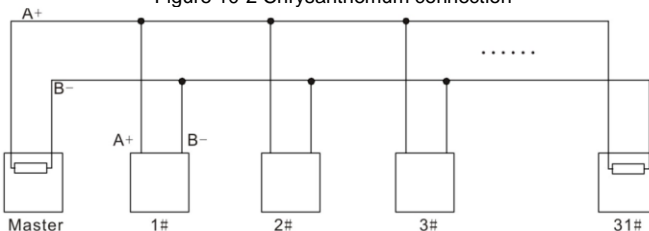

Figure 10-3 Simplified chrysanthemum connection

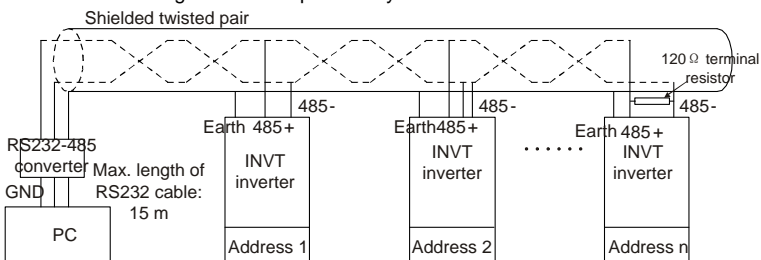

Figure 10-4 Chrysanthemum connection applications

Figure 10-5 is the star connection. Terminal resistor should be connected to the two devices which have the longest distance. (1# and 15#device)

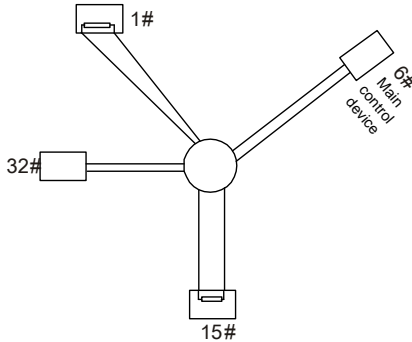

Figure 10-5 Star connection

It is recommended to use shield cables in multiple connection. The basic parameter of the devices, such as baud rate and digital check bit in RS485 should be the same and there should be no repeated address.

**10.3.2 RTU mode**

**10.3.2.1 RTU communication frame format**

If the controller is set to communicate by RTU mode in Modbus network every 8-bit byte in the message includes two 4-bit hex characters. Compared with ACSII mode, this mode can send more data at the same baud rate.

**Code system**

- 1 start bit
- 7 or 8 digital bit, the minimum valid bit can be sent firstly. Every 8 bit frame includes two hex characters (0...9, A...F)
- 1 even/odd check bit . If there is no checkout, the even/odd check bit is inexistent.
- 1 end bit (with checkout), 2 Bit(no checkout)

**Error detection field**

CRC

The data format is illustrated as below:

11-bit character frame (BIT1–BIT8 are the data bits)

Start bit	BIT1	BIT2	BIT3	BIT4	BIT5	BIT6	BIT7	BIT8	Check bit	End bit
-----------	------	------	------	------	------	------	------	------	-----------	---------

10-bit character frame (BIT1–BIT7 are the data bits)

Start bit	BIT1	BIT2	BIT3	BIT4	BIT5	BIT6	BIT7	Check bit	End bit
-----------	------	------	------	------	------	------	------	-----------	---------

In one character frame, the digital bit takes effect. The start bit, check bit and end bit is used to send the digital bit right to the other device. The digital bit, even/odd checkout and end bit should be set as the same in real application.

In RTU mode, the minimum idle time between frames should be no less than 3.5 bytes. The network device is detecting, even during the interval time, the network bus. When the first field (the address field) is received, the corresponding device decodes next transmitting character. When the interval time is at least 3.5 byte, the message ends.

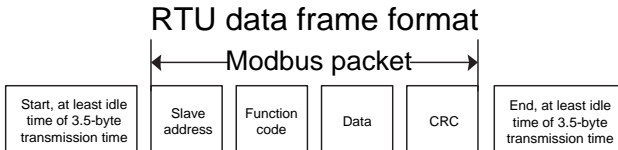

The whole message frame in RTU mode is a continuous transmitting flow. If there is an interval time (more than 1.5 bytes) before the completion of the frame, the receiving device will renew the uncompleted message and suppose the next byte as the address field of the new message. As such, if the new message follows the previous one within the interval time of 3.5 bytes, the receiving device will deal with it as the same with the previous message. If these two phenomena all happen during the transmission, the CRC will generate a fault message to respond to the sending devices.

Standard structure of RTU frame:

START	T1-T2-T3-T4 (transmission time of 3.5 bytes)
ADDR	Communication address: 0-247(decimal system)(0 is the broadcast address)
CMD	03H:read slave parameters 06H:write slave parameters
DATA (N-1) ... DATA (0)	The data of 2*N bytes are the main content of the communication as well as the core of data exchanging
CRC CHK low bit	Detection value:CRC (16BIT)
CRC CHK high bit	
END	T1-T2-T3-T4 (transmission time of 3.5 bytes)

**11.3.2.2 RTU communication frame error checkout**

Various factors (such as electromagnetic interference) may cause error in the data transmission. If there is no error checkout, the receiving devices will not find the message is wrong and they may give incorrect response which cause serious result. So the checkout is essential to the message.

The theme of checkout is that: the sender calculate the sending data according to a fixed formula, and then send the result with the message. When the receiver gets this message, they will calculate another result according to the same method and compare it with the sending one. If two results are

the same, the message is correct. If not, the message is incorrect.

The error checkout of the frame can be divided into two parts: the bit checkout of the byte and the whole data checkout of the frame (CRC check).

### Bit checkout of the byte

The user can select different bit checkouts or non-checkout, which impacts the check bit setting of each byte.

The definition of even checkout: add an even check bit before the data transmission to illustrate the number of "1" in the data transmission is odd number or even number. When it is even, the check byte is "0", otherwise, the check byte is "1". This method is used to stabilize the parity of the data.

The definition of odd checkout: add an odd check bit before the data transmission to illustrate the number of "1" in the data transmission is odd number or even number. When it is odd, the check byte is "0", otherwise, the check byte is "1". This method is used to stabilize the parity of the data.

For example, when transmitting "11001110", there are five "1" in the data. If the even checkout is applied, the even check bit is "1"; if the odd checkout is applied; the odd check bit is "0". The even and odd check bit is calculated on the check bit position of the frame. And the receiving devices also carry out even and odd checkout. If the parity of the receiving data is different from the setting value, there is an error in the communication.

### CRC check

The checkout uses RTU frame format. The frame includes the frame error detection field which is based on the CRC calculation method. The CRC field is two bytes, including 16 figure binary values. It is added into the frame after calculated by transmitting device. The receiving device recalculates the CRC of the received frame and compares them with the value in the received CRC field. If the two CRC values are different, there is an error in the communication.

During CRC, 0xFFFF will be stored. And then, deal with the continuous 6-above bytes in the frame and the value in the register. Only the 8Bit data in every character is effective to CRC, while the start bit, the end and the odd and even check bit is ineffective.

The calculation of CRC applies the international standard CRC checkout principles. When the user is editing CRC calculation, he can refer to the relative standard CRC calculation to write the required CRC calculation program.

Here provided a simple function of CRC calculation for the reference (programmed with C language):

```
unsigned int crc_cal_value(unsigned char*data_value,unsigned char data_length)
{
    int i;
    unsigned int crc_value=0xffff;
    while(data_length--)
    {
        crc_value^=*data_value++;
        for(i=0;i<8;i++)
```

```

    {
        if(crc_value&0x0001)
            crc_value=(crc_value>>1)^0xa001;
        else
            crc_value=crc_value>>1;
    }
}
return(crc_value);
}

```

In ladder logic, CKSM calculated the CRC value according to the frame with the table inquiry. The method is advanced with easy program and quick calculation speed. But the ROM space the program occupied is huge. So use it with caution according to the program required space.

## 10.4 RTU command code and communication data illustration

### 10.4.1 Command code: 03H

**03H(correspond to binary 0000 0011),read N words(Word)(the Max. continuous reading is 16 words)**

Command code 03H means that if the master read data form the inverter, the reading number depends on the "data number" in the command code. The maximum continuous reading number is 16 and the parameter address should be continuous. The byte length of every data is 2 (one word). The following command format is illustrated by hex (a number with "H" means hex) and one hex occupies one byte.

The command code is used to read the working stage of the inverter.

For example, read continuous 2 data content from 0004H from the inverter with the address of 01H (read the content of data address of 0004H and 0005H), the frame structure is as below:

RTU master command message (from the master to the inverter)

START	T1-T2-T3-T4 (transmission time of 3.5 bytes)
ADDR	01H
CMD	03H
High bit of the start bit	00H
Low bit of the start bit	04H
High bit of data number	00H
Low bit of data number	02H
Low bit of CRC	85H
High bit of CRC	CAH
END	T1-T2-T3-T4 (transmission time of 3.5 bytes)

T1-T2-T3-T4 between START and END is to provide at least the time of 3.5 bytes as the leisure time

and distinguish two messages for the avoidance of taking two messages as one message.

**ADDR** = 01H means the command message is sent to the inverter with the address of 01H and ADDR occupies one byte

**CMD**=03H means the command message is sent to read data form the inverter and CMD occupies one byte

**"Start address"** means reading data form the address and it occupies 2 bytes with the fact that the high bit is in the front and the low bit is in the behind.

**"Data number"** means the reading data number with the unit of word. If the "start address" is 0004H and the "data number" is 0002H, the data of 0004H and 0005H will be read.

**CRC** occupies 2 bytes with the fact that the high bit is in the front and the low bit is in the behind.

**RTU** slave response message (from the inverter to the master)

START	T1-T2-T3-T4 (transmission time of 3.5 bytes)
ADDR	01H
CMD	03H
Byte number	04H
Data high bit of address 0004H	13H
Data low bit of address 0004H	88H
Data high bit of address 0005H	00H
Data low bit of address 0005H	00H
Low bit of CRC	7EH
High bit of CRC	9DH
END	T1-T2-T3-T4 (transmission time of 3.5 bytes)

The meaning of the response is that:

**ADDR** = 01H means the command message is sent to the inverter with the address of 01H and ADDR occupies one byte

**CMD**=03H means the message is received from the inverter to the master for the response of reading command and CMD occupies one byte

**"Byte number"** means all byte number from the byte (excluding the byte) to CRC byte (excluding the byte). 04 means there are 4 byte of data from the "byte number" to "CRC CHK low bit", which are "digital address 0004H high bit", "digital address 0004H low bit", "digital address 0005H high bit" and "digital address 0005H low bit".

There are 2 bytes stored in one data with the fact that the high bit is in the front and the low bit is in the behind of the message, the data of data address 0004H is 1388H, and the data of data address 0005H is 0000H.

CRC occupies 2 bytes with the fact that the high bit is in the front and the low bit is in the behind.

**10.4.2 Command code: 06H****06H (correspond to binary 0000 0110), write one word(Word)**

The command means that the master writes one record of data but not multiple records of data to the inverter. The effect is to change the working mode of the inverter.

For example, write 5000 (1388H) to 0004H from the inverter with the address of 02H, the frame structure is as below:

RTU master command message (from the master to the inverter)

START	T1-T2-T3-T4 (transmission time of 3.5 bytes)
ADDR	02H
CMD	06H
High bit of writing data address	00H
Low bit of writing data address	04H
High bit of data content	13H
Low bit of data content	88H
Low bit of CRC	C5H
High bit of CRC	6EH
END	T1-T2-T3-T4 (transmission time of 3.5 bytes)

RTU slave response message (from the inverter to the master)

START	T1-T2-T3-T4 (transmission time of 3.5 bytes)
ADDR	02H
CMD	06H
High bit of writing data address	00H
Low bit of writing data address	04H
High bit of data content	13H
Low bit of data content	88H
Low bit of CRC	C5H
High bit of CRC	6EH
END	T1-T2-T3-T4 (transmission time of 3.5 bytes)

**Note:** section 10.2 and 10.3 mainly describe the command format, and the detailed application will be mentioned in 10.8 with examples.

### 10.4.3 Command code 08H for diagnosis

Meaning of sub-function codes

Sub-function Code	Description
0000	Return to inquire information data

For example: The inquiry information string is same as the response information string when the loop detection to address 01H of driver is carried out.

The RTU request command is:

START	T1-T2-T3-T4 (transmission time of 3.5 bytes)
ADDR	01H
CMD	08H
High bit of sub-function code	00H
Low bit of sub-function code	00H
High bit of data content	12H
Low bit of data content	ABH
Low bit of CRC	ADH
High bit of CRC	14H
END	T1-T2-T3-T4 (transmission time of 3.5 bytes)

The RTU response command is:

START	T1-T2-T3-T4 (transmission time of 3.5 bytes)
ADDR	01H
CMD	08H
High bit of sub-function code	00H
Low bit of sub-function code	00H
High bit of data content	12H
Low bit of data content	ABH
Low bit of CRC	ADH
High bit of CRC	14H
END	T1-T2-T3-T4 (transmission time of 3.5 bytes)

### 10.4.4 Command code: 10H, continuous writing

Command code 10H means that if the master writes data to the inverter, the data number depends on the "data number" in the command code. The maximum continuous reading number is 16.

For example, write 5000(1388H) to 0004H of the inverter whose slave address is 02H and 50 (0032H) to 0005H, the frame structure is as below:

The RTU request command is:

START	T1-T2-T3-T4 (transmission time of 3.5 bytes)
ADDR	02H
CMD	10H
High bit of write data	00H
Low bit of write data	04H
High bit of data number	00H
Low bit of data number	02H
Byte number	04H
High bit of data 0004H	13H
Low bit of data 0004H	88H
High bit of data 0005H	00H
Low bit of data 0005H	32H
Low bit of CRC	C5H
High bit of CRC	6EH
END	T1-T2-T3-T4 (transmission time of 3.5 bytes)

The RTU response command is:

START	T1-T2-T3-T4 (transmission time of 3.5 bytes)
ADDR	02H
CMD	10H
High bit of write data	00H
Low bit of write data	04H
High bit of data number	00H
Low bit of data number	02H
Low bit of CRC	C5H
High bit of CRC	6EH
END	T1-T2-T3-T4 (transmission time of 3.5 bytes)

#### 10.4.5 Data address definition

The address definition of the communication data in this part is to control the running of the inverter and get the state information and relative function parameters of the inverter.

##### 10.4.5.1 The rules of parameter address of the function codes

The parameter address occupies 2 bytes with the fact that the high bit is in the front and the low bit is in the behind. The ranges of high and low byte are: high byte—00–ffH; low byte—00–ffH. The high byte is the group number before the radix point of the function code and the low byte is the number after the radix point. But both the high byte and the low byte should be changed into hex. For example [P05.06](#), the group number before the radix point of the function code is 05, then the high bit of the parameter is 05, the number after the radix point 06, then the low bit of the parameter is 06, then the function code address is 0506H and the parameter address of [P10.01](#) is 0A01H.

P10.00	Enable non-weighting compensation	0: Disable 1: Enable	0	⊙
<b>P10.01</b>	Load compensation time	0.000~5.000s	0.400	⊙

**Note:** P29 group is the factory parameters which cannot be read or changed. Some parameters cannot be changed when the inverter is in the running state and some parameters cannot be changed in any state. The setting range, unit and relative instructions should be paid attention to when modifying the function code parameters.

Besides, EEPROM is stocked frequently, which may shorten the usage time of EEPROM. For users, some functions are not necessary to be stocked on the communication mode. The needs can be met on by changing the value in RAM. Changing the high bit of the function code from 0 to 1 can also realize the function. For example, the function code [P00.07](#) is not stocked into EEPROM. Only by changing the value in RAM can set the address to 8007H. This address can only be used in writing RAM other than reading. If it is used to read, it is an invalid address.

**10.4.5.2 The address instruction of other function in Modbus**

The master can operate on the parameters of the inverter as well as control the inverter, such as running or stopping and monitoring the working state of the inverter.

Below is the parameter list of other functions:

Function instruction	Address definition	Data meaning instruction	R/W property
Communication control command	2000H	0001H: Forward running	W/R
		0002H: Reverse running	
		0003H: Forward jogging	
		0004H: Reverse jogging	
		0005H: Stop	
		0006H: Coast to stop (emergency stop)	
		0007H: Fault reset	
		0008H: Jogging stop	
The address of communication setting	2001H	Communication setting frequency (0–Fmax, unit: 0.01Hz)	W/R
	2002H	PID given, range (0–1000, 1000 corresponds to 100.0%)	
	2003H	PID feedback, range (0–1000, 1000 corresponds to 100.0%)	W/R
	2004H	Torque setting value (-3000–3000, 1000 corresponds to the 100.0% of the rated current of the motor)	W/R
	2005H	The upper limit frequency setting during forward	W/R

Function instruction	Address definition	Data meaning instruction	R/W property
		rotation (0–Fmax, unit: 0.01Hz)	
	2006H	The upper limit frequency setting during reverse rotation (0–Fmax, unit: 0.01Hz)	W/R
	2007H	The upper limit torque of electromotion torque (0–3000, 1000 corresponds to the 100.0% of the rated current of the motor)	W/R
	2008H	The upper limit torque of braking torque (0–3000, 1000 corresponds to the 100.0% of the rated current of the motor)	W/R
	2009H	Special control command word Bit0–1:=00: motor 1 =01: motor 2 =10: motor 3 =11: motor 4 Bit2:=1 torque control prohibit =0: torque control prohibit invalid Bit3:=1 power consumption clear =0:no power consumption clear Bit4:=1 pre-exciting enabling =0: pre-exciting disabling Bit5:=1 DC braking enabling =0: DC braking disabling	W/R
	200AH	Virtual input terminal command, range: 0x000–0x1FF	W/R
	200BH	Virtual output terminal command , range: 0x00–0x0F	W/R
	200CH	Voltage setting value(special for V/F separation) (0–1000, 1000 corresponds to the 100.0%)	W/R
	200DH	AO output setting 1 (-1000–1000, 1000 corresponds to 100.0%)	W/R
	200EH	AO output setting 2 (-1000–1000, 1000 corresponds to 100.0%)	W/R
	SW 1 of the inverter	2100H	0001H:forward running
0002H:forward running			
0003H:stop			
0004H:fault			
0005H: POFF state			
0006H: pre-exciting state			

Function instruction	Address definition	Data meaning instruction	R/W property
SW 2 of the inverter	2101H	Bit0: =0: ready for operation =1: not ready for operation Bi1–2:=00:motor 1 =01:motor 2 =10:motor 3 =11:motor 4 Bit3: =0:asynchronous motor =1:synchronous motor Bit4: =0:pre-alarm without overload =1:overload pre-alarm Bit5–Bit6: =00: keypad control =01: terminal control =10: communication control	R
Fault code of the inverter	2102H	See the fault type instruction	R
Identifying code of the inverter	2103H	GD300----0x010a	R
Operation frequency	3000H	0–Fmax (unit: 0.01Hz)	R
Setting frequency	3001H	0–Fmax (unit: 0.01Hz)	R
Bus voltage	3002H	0.0–2000.0V (unit: 0.1V)	R
Output voltage	3003H	0–1200V (unit: 1V)	R
Output current	3004H	0.0–3000.0A (unit: 0.1A)	R
Rotation speed	3005H	0–65535 (unit: 1RPM)	R
Output power	3006H	-300.0–300.0% (unit: 0.1%)	R
Output torque	3007H	-250.0–250.0% (unit: 0.1%)	R
Close loop setting	3008H	-100.0–100.0% (unit: 0.1%)	R
Close loop feedback	3009H	-100.0–100.0% (unit: 0.1%)	R
Input IO state	300AH	000–1FF	R
Output IO state	300BH	000–1FF	R
Analog input 1	300CH	0.00–10.00V (unit: 0.01V)	R
Analog input 2	300DH	0.00–10.00V (unit: 0.01V)	R
Analog input 3	300EH	-10.00–10.00V (unit: 0.01V)	R
Analog input 4	300FH		R
Read input of	3010H	0.00–50.00kHz (unit: 0.01Hz)	R

Compatible with CHF100A/CHV100 communication address

Function instruction	Address definition	Data meaning instruction		R/W property
high-speed pulse 1				
Read input of high-speed pulse 2	3011H			R
Read the current stage of multi-step speed	3012H	0-15		R
External length	3013H	0-65535		R
External counting	3014H	0-65535		R
Torque setting	3015H	-300.0-300.0% (unit: 0.1%)		R
Identifying code of the inverter	3016H			R
Fault code	5000H			R

R/W characteristics means the function is with read and write characteristics. For example, "communication control command" is writing characteristics and control the inverter with writing command (06H). R characteristic can only read other than write and W characteristic can only write other than read.

**Note:** when operate on the inverter with the table above, it is necessary to enable some parameters. For example, the operation of running and stopping, it is necessary to set [P00.01](#) to communication running command channel and set [P00.02](#) to MODBUS communication channel. And when operate on "PID given", it is necessary to set [P09.00](#) to "MODBUS communication setting".

The encoding rules for device codes (corresponds to identifying code 2103H of the inverter)

High 8 bit	Meaning	Low 8 bit	Meaning
01	GD	0x08	GD35 vector inverter
		0x09	GD35-H1 vector inverter
		0x0a	GD300 vector inverter
		0x0b	GD100 simple vector inverter
		0x0c	GD200 universal inverter
		0x0d	GD10 mini inverter

#### 10.4.6 Fieldbus ratio values

The communication data is expressed by hex in actual application and there is no radix point in hex. For example, 50.12Hz cannot be expressed by hex so 50.12 can be magnified by 100 times into 5012, so hex 1394H can be used to express 50.12.

A non-integer can be timed by a multiple to get an integer and the integer can be called fieldbus ratio

values.

The fieldbus ratio values are referred to the radix point of the setting range or default value in the function parameter list. If there are figures behind the radix point (n=1), then the fieldbus ratio value m is  $10^n$ . Take the table as the example:

P09.11	ACC time	0.1 - 360.0s	2.0	⊙
--------	----------	--------------	-----	---

If there is one figure behind the radix point in the setting range or the default value, then the fieldbus ratio value is 10. if the data received by the upper monitor is 50, then the "hibernation restore delay time" is 5.0 (5.0=50÷10).

If Modbus communication is used to control the hibernation restore delay time as 5.0s. Firstly, 5.0 can be magnified by 10 times to integer 50 (32H) and then this data can be sent.

<b><u>01</u></b>	<b><u>06</u></b>	<b><u>09 0B</u></b>	<b><u>00 32</u></b>	<b><u>7A 41</u></b>
Inverter address	Write command	Parameter address	Parameter data	CRC

After the inverter receives the command, it will change 50 into 5.0 according to the fieldbus ratio value and then set the hibernation restore delay time as 5.0s.

Another example, after the upper monitor sends the command of reading the parameter of hibernation restore delay time, if the response message of the inverter is as following:

<b><u>01</u></b>	<b><u>03</u></b>	<b><u>02</u></b>	<b><u>00 32</u></b>	<b><u>49 E7</u></b>
Inverter address	Read command	Two bytes of data	Parameter data	CRC

Because the parameter data is 0032H (50) and 50 divided by 10 is 5.0, then the hibernation restore delay time is 5.0s.

#### 10.4.7 Fault message response

There may be fault in the communication control. For example, some parameter can only be read. If a writing message is sent, the inverter will return a fault response message.

The fault message is from the inverter to the master, its code and meaning is as below:

Code	Name	Meaning
01H	Illegal command	The command from master cannot be executed. The reason maybe: 1. This command is only for new device; 2. Slave is in fault state and cannot execute it.
02H	Illegal data address.	Some of the operation addresses are invalid or not allowed to access. Especially the combination of the register and the transmitting bytes are invalid.
03H	Illegal value	When there are invalid data in the message framed received by slave. <b>Note:</b> This error code does not indicate the data value to write exceed

Code	Name	Meaning
		the range, but indicate the message frame is an illegal frame.
04H	Operation failed	The parameter setting in parameter writing is invalid. For example, the function input terminal cannot be set repeatedly.
05H	Password error	The password written to the password check address is not same as the password set by <a href="#">P07.00</a> .
06H	Data frame error	In the frame message sent by the upper monitor, the length of the digital frame is incorrect or the counting of CRC check bit in RTU is different from the lower monitor.
07H	Parameters only for read	It only happen in write command
08H	Parameters cannot be changed during running	The modified parameter in the writing of the upper monitor cannot be modified during running.
09H	Password protection	When the upper monitor is writing or reading and the user password is set without password unlocking, it will report that the system is locked.

The slave uses functional code fields and fault addresses to indicate it is a normal response or some error occurs (named as objection response). For normal responses, the slave shows corresponding function codes, digital address or sub-function codes as the response. For objection responses, the slave returns a code which equals the normal code, but the first byte is logic 1.

For example: when the master sends a message to the slave, requiring it to read a group of address data of the inverter function codes, there will be following function codes:

0 0 0 0 0 1 1 (Hex 03H)

For normal responses, the slave responds the same codes, while for objection responses, it will return:

1 0 0 0 0 1 1 (Hex 83H)

Besides the function codes modification for the objection fault, the slave will respond a byte of abnormal code which defines the error reason.

When the master receives the response for the objection, in a typical processing, it will send the message again or modify the corresponding order.

For example, set the "running command channel" of the inverter ([P00.01](#), parameter address is 0001H) with the address of 01H to 03, the command is as following:

<b><u>01</u></b>	<b><u>06</u></b>	<b><u>00 01</u></b>	<b><u>00 03</u></b>	<b><u>98 0B</u></b>
Inverter address	Read command	Parameter address	Parameter data	CRC

But the setting range of "running command channel" is 0–2, if it is set to 3, because the number is beyond the range, the inverter will return fault response message as below:

<b><u>01</u></b>	<b><u>86</u></b>	<b><u>04</u></b>	<b><u>43 A3</u></b>
Inverter address	Exception response code	Error code	CRC

Abnormal response code 86H means the abnormal response to writing command 06H; the fault code is 04H. In the table above, its name is operation failed and its meaning is that the parameter setting in parameter writing is invalid.

### 10.4.8 Example of writing and reading

Refer to 10.4.1 and 10.4.2 for the command format.

#### 10.4.8.1 Example of reading command 03H

Read the state word 1 of the inverter with the address of 01H (refer to table 1). From the table 1, the parameter address of the state word 1 of the inverter is 2100H.

The command sent to the inverter:

<b><u>01</u></b>	<b><u>03</u></b>	<b><u>21 00</u></b>	<b><u>00 01</u></b>	<b><u>8E 36</u></b>
Inverter address	Read command	Parameter address	Data quantity	CRC

If the response message is as below:

<b><u>01</u></b>	<b><u>03</u></b>	<b><u>02</u></b>	<b><u>00 03</u></b>	<b><u>F8 45</u></b>
Inverter address	Read command	Number of bytes	Data content	CRC

The data content is 0003H. From the table 1, the inverter stops.

Watch "Type of current fault" to "Type of last but four fault" of the inverter through commands, the corresponding function code is [P07.27–P07.32](#) and corresponding parameter address is 071BH–0720H (there are 6 from 071BH).

The command sent to the inverter:

<b><u>03</u></b>	<b><u>03</u></b>	<b><u>07 1B</u></b>	<b><u>00 06</u></b>	<b><u>B5 59</u></b>
Inverter address	Read command	Start address	6 parameters in total	CRC

If the response message is as below:

<b><u>01</u></b>	<b><u>03</u></b>	<b><u>0C</u></b>	<b><u>00 23</u></b>	<b><u>00 23</u></b>	<b><u>00 23</u></b>	<b><u>00 23</u></b>	<b><u>00 23</u></b>	<b><u>00 23</u></b>	<b><u>00 23</u></b>	<b><u>5F D2</u></b>
Inverter address	Read command	Number of bytes	Type of current fault	Type of last fault	Type of last but one fault	Type of last but two fault	Type of last but three fault	Type of last but four fault		CRC

See from the returned data, all fault types are 0023H (decimal 35) with the meaning of maladjustment (STo).

**10.4.8.2 Example of writing command 06H**

Make the inverter with the address of 03H to run forward. The address of "communication control command" is 2000H and forward running is 0001. See the figure below.

Function instruction	Address definition	Data meaning instruction	R/W property
Communication control command	2000H	0001H:forward running	W/R
		0002H:reverse running	
		0003H:forward jogging	
		0004H:reverse jogging	
		0005H:stop	
		0006H:coast to stop (emergency stop)	
		0007H:fault reset	
		0008H:jogging stop	

The command sent by the master:

**03**      **06**      **20 00**      **00 01**      **42 28**  
 Inverter address      Write command      Parameter address      Forward running      CRC

If the operation is success, the response may be as below (the same with the command sent by the master):

**03**      **06**      **20 00**      **00 01**      **42 28**  
 Inverter address      Write command      Parameter address      Forward running      CRC

Set the max. output frequency of the inverter with the address of 03H as 100Hz.

P00.04	Max. output frequency	10.00~600.00Hz	50.00 Hz	©
--------	-----------------------	----------------	----------	---

See the figures behind the radix point, the fieldbus ratio value of the Max. output frequency ([P00.04](#)) is 100. 100Hz timed by 100 is 10000 and the corresponding hex is 2710H.

The command sent by the master:

**03**      **06**      **00 04**      **27 10**      **D3 D5**  
 Inverter address      Write command      Parameter address      Data quantity      CRC

If the operation is successful, the response may be as below (the same as the command from the master):

03            06            00 04            27 10            D3 D5  
 Inverter        Write        Parameter        Data quantity        CRC  
 address        command        address

**Note:** The spaces in the above command are for illustration. No space can be added in the actual application unless the upper monitor can remove spaces.

**10.4.8.3 Example of continuous writing command10H**

Example 1: Make the inverter whose address is 01H run forward at 10Hz. Refer to the instruction of 2000H and 0001. Set the address of "communication setting frequency" to 2001H and 10Hz corresponds to 03E8H. See the table below.

Function instruction	Address definition	Data meaning instruction	R/W property
Communication control command	2000H	0001H: Forward running	W/R
		0002H: Reverse running	
		0003H: Forward jogging	
		0004H: Reverse jogging	
		0005H: Stop	
		0006H: Coast to stop (emergency stop)	
		0007H: Fault reset	
		0008H: Jogging stop	
The address of communication setting	2001H	Communication setting frequency (0–Fmax, unit: 0.01Hz)	W/R
	2002H	PID given, range (0–1000, 1000 corresponds to100.0%)	

Set [P00.01](#) to 2.

The command sent to the inverter:

01    10    20 00    00 02    04    00 01    03 E8    3B 10  
 Inverter    Continuous    Parameter    Parameter    Number of    Forward    10 Hz    CRC  
 address    write    address    quantity    bytes    running

If the operation is successful, the response message is as below:

01    10    20 00    00 02    4A 08  
 Inverter    Continuous    Parameter    Parameter    CRC  
 address    write    address    quantity

Example 2: set the S-curve ACC start segment duration of 01H inverter as 2s and the S-curve ACC end segment duration as 3s

<a href="#">P09.09</a>	S-curve ACC start segment duration	0.1–360.0s	2.0	⊙
<a href="#">P09.10</a>	S-curve ACC end segment duration	0.1–360.0s	2.0	⊙

The address of [P09.09](#) is 0909, 2s corresponds to 0014H, and 3s corresponds to 001EH.

The command sent to the inverter:

**01**   **10**   **09 09**   **00 02**   **04**   **00 14**   **00 1E**   **99 99**  
 Inverter address   Continuous write command   Parameter address   Parameter quantity   Number of bytes   2s   3s   CRC

If the operation is successful, the response message is as follows:

**01**   **10**   **09 09**   **00 02**   **30 0A**  
 Inverter address   Continuous write command   Parameter address   Parameter quantity   CRC

**Note:** The spaces in the above command are for illustration. No space can be added in the actual application unless the upper monitor can remove spaces.

**10.4.8.4 MODBUS communication commissioning example**

Assume that the master is a PC which uses RS232-RS485 converter to convert signals. The converter uses the PC serial port COM1 (RS232 port). The upper monitor commissioning software is the serial port commissioning assistant Commix 1.4, which is available in the Internet. It is recommended to use the software with the CRC function. The figure below shows an interface example of the software.

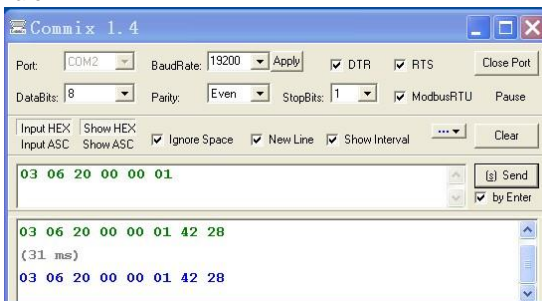

Set "Port" to "COM2". Set "BaudRate" to the value the same as that of [P14.01](#). Keep "DataBits", "Parity", and "StopBits" consistent with the setting of [P14.02](#). In RTU mode, select "HEX". If CRC must be enabled, select "ModbusRTU" and "CRC16(MODBUSRTU)", and set the starting byte to "1". Once after CRC is automatically enabled, you must not enter CRC in commands. Otherwise, repeated setting will cause command errors.

The commissioning command below enables the inverter with the address set to 03H to rotate

forward (example 1 in section 10.4.7.2):

03 06 20 00 00 01

**Note:**

The inverter address ([P14.00](#)) must be set to 03.

Set [P00.01](#) to "communication operation command channel" and [P00.02](#) to "MODBUS communication channel".

If the route and settings are correct, you will receive the response from the inverter after clicking "Send".

## 10.5 Common communication faults

Common communication faults: no communication response or abnormal inverter response.

The possible causes of no communication response are as follows:

Selecting wrong serial interface, for example, if the converter is COM1, selecting COM2 during the communication

The baud rate, digital bit, end bit and check bit are not the same with the inverter + and - of RS485 are connected in reverse.

The 485 wire cap on the terminal board of the inverter is not plug in. the wire cap in behind the terminal arrangement.

## Appendix A Expansion cards

### A.1 What this chapter contains

This chapter describes the extension cards used in GD300L series inverters special for lifts.

### A.2 I/O expansion card

#### A.2.1 Terminals and jumpers of I/O expansion card

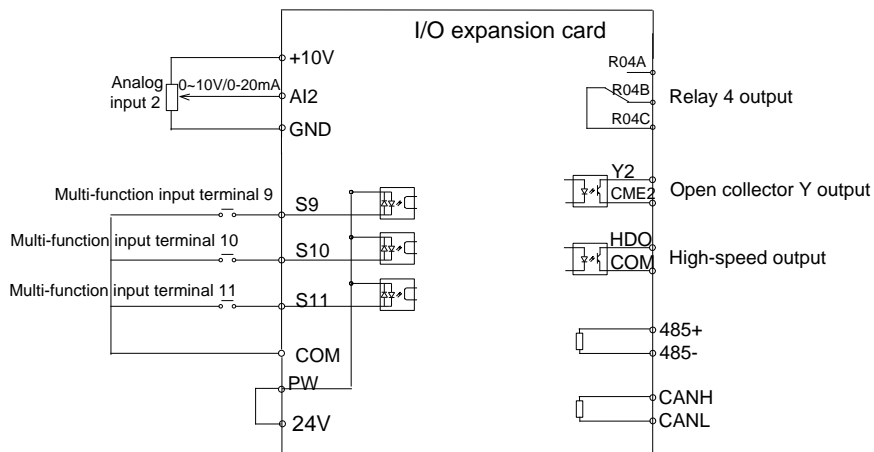

Figure A-1 IO extension card terminals and jumpers

#### Terminals

Terminal	Usage and instruction
S9-S11	ON-OFF signal input, optical coupling isolation input terminal with PW and COM. Input voltage range: 9-30V Input impedance: 3.3kΩ
HDO	High-speed output terminal
+24V	24V power supply
PW	External power input terminal
COM	Common terminal of +24V or external power supply
GND	Reference zero potential of +10V
Y2	Open collector output terminal, the corresponding common ground terminal is CME. External voltage range: 0-24V Output current range: 0-50mA
CME2	Common terminal of open collector output

Terminal	Usage and instruction
A12	Analog input terminal Output range: 0–10V/0–20mA, switched by J3
RO4A RO4B RO4C	Relay output: RO4A common; RO3B NC; RO3C NO Contact capacity: AC250V/3A, DC30V/1A
RS485+ RS485-	RS485 serial port communication, supporting Modbus RTU
CANH CANL	CAN communication interface, supporting the CAN communication protocol

**Note:** GND and COM are isolated.

**Jumpers**

Jumper	Description
J1	RS485 communication end resistor connection terminal. ON indicates connecting to the end resistor. The default is not connecting to the end resistor.
J2	PE and GND short-circuited terminal, no short circuited by default.
J3	I corresponds to current signal while V corresponds to voltage signal. The default is the current input signal.

**A.2.2 Dimensions and terminal layout**

**I/O expansion card dimensions and sketch map**

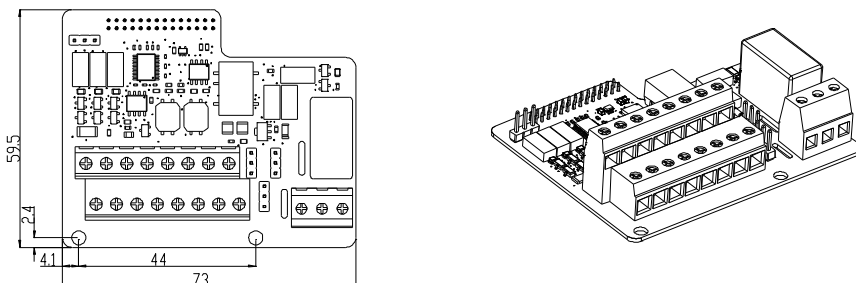
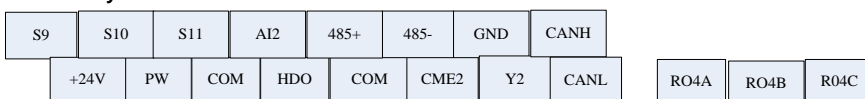

Figure A-2 I/O expansion card dimensions and sketch map

**Terminal layout**



### A.2.3 I/O expansion card installation

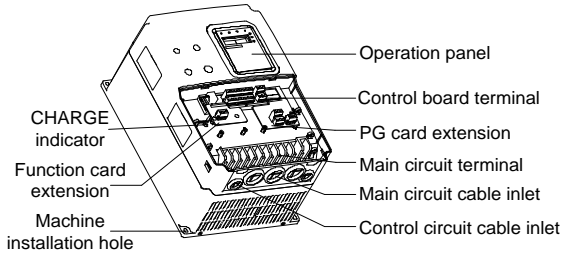

Figure A-3 I/O expansion card and PG card installation

## A.3 Asynchronous motor PG card

### A.3.1 Models and specifications

#### A.3.1.1 Model descriptions and technical specifications

The asynchronous PG card of GD300L series inverters is PN000PGWX. Below is the specification table.

Terminal	Specifications
12V, COM1	Power supply of the encoder Max. output current: 300mA
TERA+ TERA- TERB+ TERB-	Input channel of the encoder signal Voltage range: 12–15V Response speed: 0–80kHz
TER-OA TER-OB	Output frequency: 0–80kHz Output impedance: 30Ω Frequency range: 1–256

#### A.3.1.2 Dimensions and installation of the asynchronous motor PG card

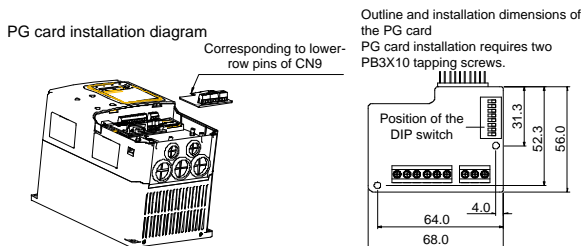

Figure A-4 Dimensions and installation of the asynchronous PG card

**Note:** The asynchronous PG card is inserted in the lower pins of the control board CN9. The synchronous PG card is inserted in CN9.

### A.3.2 Operating Instructions of the asynchronous motor PG card

#### A.3.2.1 Functions

When the asynchronous motor uses PG vector control, it is necessary to select the asynchronous motor PG Card. The function of PG card includes 2 ways of processing circuit for orthogonal encoder signal and it can receive differential, open collector and push-pull output signal and the power supply of the encoder (+12V); it can also output frequency division for the encoder signal (the output is 2 ways of orthogonal open collector signal). Select according to the actual use.

#### A.3.2.2 Terminals and DIP

There are 9 wiring terminals in asynchronous PG card:

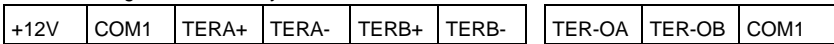

Figure A-5 Wiring terminals in asynchronous PG card

Among them, +12V and COM1 are the power supply output for the encoder; TERA+, TERA-, TERB+ and TERB- are the input terminal for the encoder; TER-OA, TER-OB and COM1 are the output terminal for frequency division signal and there is no PE in the internal of the card, so the user can ground by themselves during use.

The frequency coefficient of asynchronous PG card is determined by the DIP switch on the card. There are 8 switches and the frequency coefficient is decided by the shown binary figures that are added by 1. "1" on the switch is the low bit and "8" is the high bit. When the DIP is switched to ON, the bit is valid, reverse it is "0".

Frequency division coefficient:

Decimal digit	Binary digit	Frequency division factor
0	00000000	1
1	00000001	2
2	00000010	3
...	...	...
m	...	m+1
255	11111111	256

**A.3.2.3 Wiring diagram**

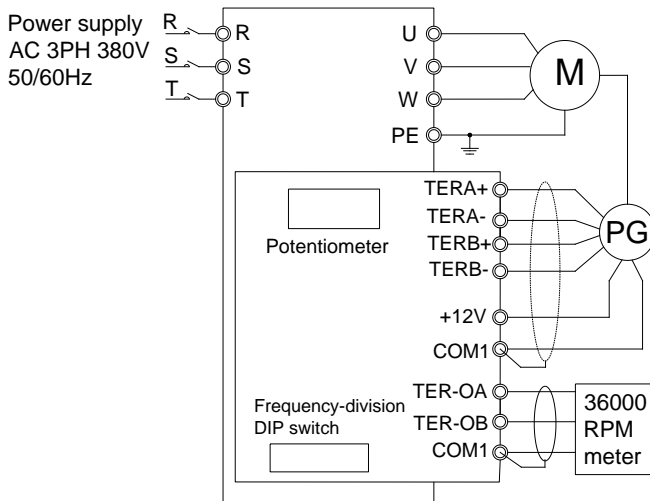

Figure A-6 Wiring diagram of the asynchronous PG card

**A.3.2.4 Wiring precautions**

The signal wire of the PG card should be routed separately from the power lines.

Please select the shield cables as the PG signal wire for the avoidance of encoder signal.

The shield layer of the encoder cables should be founded with one end (for example, the PE end of the inverter) for the avoidance of the signal interference.

If the frequency division output of the PG card is connected with the user power supply, the voltage is less than 24V, otherwise, the PG card may be damaged.

**A.3.3 Application connection**

(1) Wiring diagram of differential output encoder

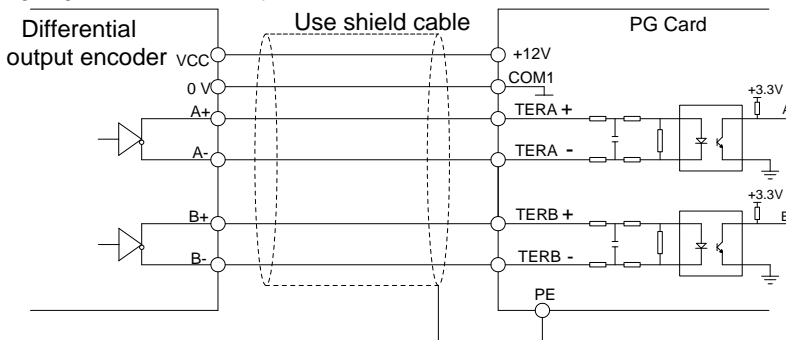

Figure A-7 Wiring diagram of differential output encoder

(2) Wiring diagram of open collector output encoder

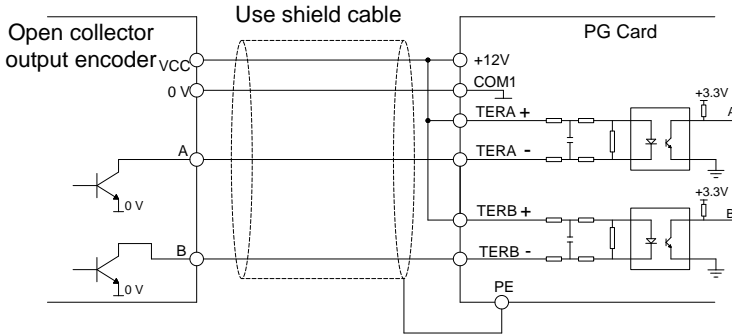

Figure A-8 Wiring diagram of open collector output encoder

(3) Wiring diagram of push-pull output encoder

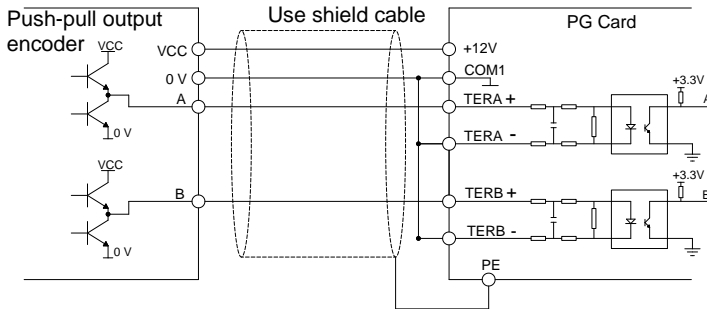

Figure A-9 Wiring diagram of push-pull output encoder

(4) Wiring diagram of PG card frequency-division output

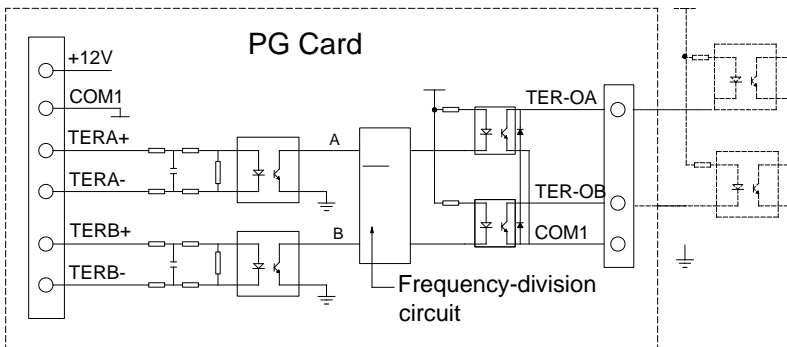

Figure A-10 Wiring diagram of PG card frequency-division output

## A.4 Synchronous motor PG card

### A.4.1 Models and specifications

The synchronous PG card is compatible with UVW encoder and SIN/COS encoder. There are two types of model:

Model of PG card	CHV180-SY-PG-UVW	CHV180-SY-PG-SIN
The supported encoder types	UVW encoder	SIN/COS encoder
Frequency division coefficient	1–256(with dial switching)	1(without dial switching)
Encoder voltage	5V/±5%	5V/±5%
Signal port of PG	Same with the description of section 7.4.3	Same with the description of section 7.4.3.

Select the card according to the actual requirement.

#### A.4.2 Dimensions and schematic diagram of the synchronous motor PG card for UUV encoders

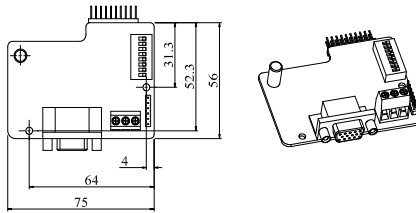

Figure A-11 Dimensions and schematic diagram of the UUV-type synchronous motor PG card

#### Note:

- The installation position and method of the synchronous motor PG card are the same as that of the asynchronous motor PG card, but the contact pin has two lines, the contact pin of asynchronous motor PG card is only one line (the lower line of CN9).
- The dimension of SIN/COS type synchronous PG is consistent with UUV type PG card only without dial switching for frequency division.
- The PG card of asynchronous motor is used in all CHV and GD300L series inverters, but the PG card of synchronous motor is only used to GD300L inverter. When user is using the synchronous tractor, they must select the PG card of synchronous motor.

#### A.4.3 Terminals and dial switch

The PG card has one signal wire port and 3 user terminals (output signal of frequency division) shown as Figure A-12.

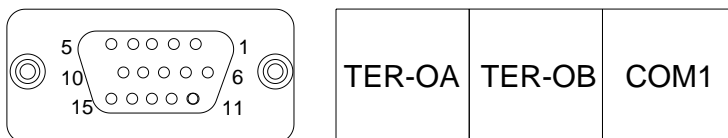

**DB15 Frequency division output**

Figure A-12 PG card wire port and wire terminals

TER-OA, TER-OB and COM1 are the signal terminals of frequency division output.

**Note:** PE terminal in PG card are not grounded to the earth, so users can grounding it by themselves.

DB15 is the port of the encoder input signal. The sequence of the ports signal is as below:

Port	SIN/COS	UVW
8	A	A
3	A-	A-
9	B	B
4	B-	B-
15	R	Z
14	R-	Z-
6	C	U
1	C-	U-
7	D	V
2	D-	V-
12	5V	5V
13	0V	0V
10	Empty	W
5	Empty	W-
11	Empty	Empty

When using the synchronous PG card, it is necessary to insert the connecting wire of SIN/COS or UVW whose signal array is corresponding with PG card into DB15 of PG card.

The frequency division coefficient is determined by the dial switch on the card. The dial switch consists of 8 bits. The frequency division is decided by the value of the binary digits (at dial switch) plus 1. The bit marked as "1" on the DIP switch is the lower binary bit, while "8" is the higher binary bit. When the dial switch is switched to ON, the bit is valid, indicating "1"; otherwise, it is invalid, and it is indicating "0".

Frequency division coefficients are shown in the table below:

Decimal digit	Binary digit	Frequency division coefficients
0	00000000	1
1	00000001	2
2	00000010	3
...	...	...
m	...	m+1
255	11111111	256

## A.5 STO instructions

### A.5.1 STO function overview

Reference standards: IEC 61508-1, IEC 61508-2, IEC 61508-3, IEC 61508-4, IEC 62061, ISO 13849-1, and IEC 61800-5-2

You can enable the safe torque off (STO) function to prevent unexpected startups when the main power supply of the drive is not switched off. The STO function switches off the drive output by turning off the drive signals to prevent unexpected startups of the motor (see Figure A-13). After the STO function is enabled, you can perform short-time operations (such as non-electrical cleaning in the lathe industry) and maintain the non-electrical components of the device without switching off the drive.

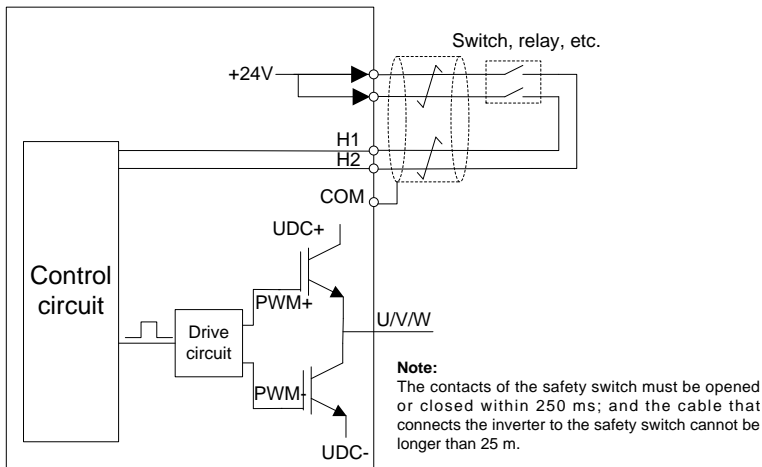

Figure A-13 STO function schematic

### A.5.2 STO function features

#### 1. STO function logic

The following table describes the input states and corresponding faults of the STO function.

STO input state	Corresponding fault
H1 and H2 opened simultaneously	The STO function is triggered, and the drive stops running. Fault code: 40: Safe torque off (SAFE)
H1 and H2 closed simultaneously	The STOP function is not triggered, and the drive runs properly.
One of H1 and H2 opened, and the other closed	The STL1, STL2, or STL3 fault occurs. Fault code: 38: Channel H1 exception (STL1) 39: Channel H2 exception (STL2) 40: Channel H1 and H2 exceptions (STL3)

2. STO channel delay description

The following table describes the trigger and indication delay of the STO channels.

STO mode	STO trigger and indication delay <sup>1), 2)</sup>
STO fault: STL1	Trigger delay < 10 ms Indication delay < 280 ms
STO fault: STL2	Trigger delay < 10 ms Indication delay < 280 ms
STO fault: STL3	Trigger delay < 10 ms Indication delay < 280 ms
STO fault: SAFE	Trigger delay < 10 ms Indication delay < 100 ms

1) STO function trigger delay: Time interval between triggering the STO function and switching off the drive output

2) STO indication delay: Time interval between triggering the STO function and STO output state indication

3. STO function installation checklist

Before installing the STO, check the items described in the following table to ensure that the STO function can be properly used.

	Item
<input type="checkbox"/>	Ensure that the drive can be run or stopped randomly during commissioning.
<input type="checkbox"/>	Stop the drive (if it is running), disconnect the input power supply, and isolate the drive from the power cable through the switch.
<input type="checkbox"/>	Check the STO circuit connection according to the circuit diagram.
<input type="checkbox"/>	COM Check whether the shielding layer of the STO input cable is connected to the +24 V reference ground COM.

<input type="checkbox"/>	Connect the power supply.
<input type="checkbox"/>	Test the STO function as follows after the motor stops running: <ul style="list-style-type: none"> <li>• If the drive is running, send a stop command to it and wait until the shaft of the motor stops rotating.</li> <li>• Activate the STO circuit and send a start command to the drive. Ensure that the motor does not start.</li> <li>• Deactivate the STO circuit.</li> </ul>
<input type="checkbox"/>	Restart the drive, and check whether the motor is running properly.
<input type="checkbox"/>	Test the STO function as follows when the motor is running: <ul style="list-style-type: none"> <li>• Start the drive. Ensure that the motor is running properly.</li> <li>• Activate the STO circuit.</li> <li>• The drive reports an STO fault (for details, see section 8.5 "Inverter faults and solutions"). Ensure that the motor coasts to stop rotating.</li> <li>• Deactivate the STO circuit.</li> </ul>
<input type="checkbox"/>	Restart the drive, and check whether the motor is running properly.

**A.5.3 STO function list**

Function code	Name	Detailed parameter description	Default value	Modify
<a href="#">P06.01</a>	Y1 output	0: No output	27	○
<a href="#">P06.03</a>	Relay output RO1	1: Lift in operation 2: Up operation 3: Down operation 4: Fault output		
<a href="#">P06.04</a>	Relay output RO2	5: Zero speed running 6: Ready for running 7: Braking control 8: Contactor control 9: Frequency arrival 10: Frequency detection threshold (FDT) output 11: FDT reverse output 12: Reserved 13: Light-load direction detection completed 14: Down as the light-load direction detection result 15: Up as the light-load direction detection result 16: Running 1 (excluding current withdrawal) 17: STO operation 18: SPI fault output 19: UPS control signal output (for India) 20: Reserved	5	○

Function code	Name	Detailed parameter description	Default value	Modify
<a href="#">P07.28</a>	Type of current fault	0: No fault		●
<a href="#">P07.29</a>	Type of last fault	1: Inverter unit U phase protection (OUt1) 2: Inverter unit V phase protection (OUt2) 3: Inverter unit W phase protection (OUt3)		●
<a href="#">P07.30</a>	Type of last but one fault	4: ACC overcurrent (OC1) 5: DEC overcurrent (OC2) 6: Constant-speed overcurrent (OC3)		●
<a href="#">P07.31</a>	Type of last but two fault	7: ACC overvoltage (OV1) 8: DEC overvoltage (OV2) 9: Constant-speed overvoltage (OV3)		●
<a href="#">P07.32</a>	Type of last but three fault	10: Bus undervoltage (UV) 11: Motor overload (OL1)		●
<a href="#">P07.33</a>	Type of last but four	12: Inverter overload (OL2) 13: Input side phase loss (SPI) 14: Output side phase loss (SPO) 15: Overheat of the rectifier module (OH1) 16: Overheat fault of the converter module (OH2) 17: External fault (EF) 18: 485 communication fault (CE) 19: Current detection fault (ItE) 20: Motor autotune fault (tE) 21: EEPROM operation fault (EEP) 22: PID response offline fault (PIDE) 23: Brake unit fault (bCE) 24: Running time arrival (END) 25: Electrical overload (OL3) 26: Panel communication fault (PCE) 27: Parameter uploading fault (UPE) 28: Parameter downloading fault (DNE) 29: PROFIBUS communication fault (E-DP) 30: Ethernet communication fault (E-NET) 31: CANopen communication fault (E-CAN)		●

Function code	Name	Detailed parameter description	Default value	Modify
		32: Short-to-ground fault 1 (ETH1) 33: Short-to-ground fault 2 (ETH2) 34: Speed deviation fault (dEu) 35: Maladjustment (STo) 36: Undervoltage fault (LL) 37: Encoder offline fault (ENC1O) 38: Encoder reverse fault (ENC1D) 39: Encoder Z pulse offline fault (ENC1Z) 40: U disconnection (ENC1U) 41–42: Reserved 43: Motor overtemperature fault (OT) 44: Reserved 45: Braking fault (BAE) 46: Contactor fault (CONE) 47: No CD signal (nPoS) 48: No enabling signal (U-EN) 49: STO card fault (SAFE) 50: Channel 1 (STO1_FB_DSP) safety circuit exception (STL1) 51: Channel 2 (STO1_FB_DSP) safety circuit exception (STL2) 52: Internal circuit exception (STL3) 53: Safety code FLASH CRC fault (CrCE)		
<a href="#">P15.00</a>	Expansion card type	0: No 1: STO 2: IO 3: Bluetooth	0	

Function code	Name	Detailed parameter description	Default value	Modify
<a href="#">P15.01</a>	STO function setting	<p>0: STO alarm locked (the SAFE fault can be reset)</p> <p>Alarm locking refers to that after a SAFE fault occurs and the state is restored, you need to manually reset.</p> <p>1: STO alarm not locked</p> <p>No alarm locking refers to that after a SAFE fault occurs and the state is restored, the alarm is automatically deleted.</p> <p><b>Note:</b> All of STL1 to STL3 faults are set to alarm locked, and cannot be reset. After the state is restored, you need to apply power again for reset.</p>	0	○

#### A.5.4 STO faults

Fault code	Fault type	Possible cause	Solution
STO	Safe torque off	The STO function is running properly (SAFE).	
STL1	Channel H1 exception	Faults occur on channel H1 or internal hardware circuits.	Replace the STO switch. If the fault persists, contact the manufacturer.
STL2	Channel H2 exception	Faults occur on channel H3 or internal hardware circuits.	
STL3	Channels H1 and H2 exception	Faults occur on channels H1 and H2 or internal hardware circuits.	
CrCE	Safety code FLASH CRC fault	Errors occur in the STO safety code FLASH CRC.	Contact the manufacturer.

#### 1. SAFE alarm

- (1) When [P15.01](#) is set to 0, the SAFE alarm function is locked.

As shown in Figure A-14, when H1 and H2 go off (the safety function is required), the drive enters the safe operation mode and stops output. After reset is successfully performed, the

SAFE alarm is deleted. The drive executes the running command only after it is reset and the external running command is reset.

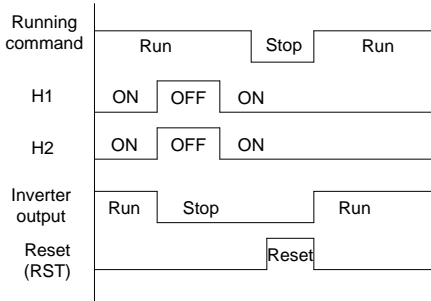

Figure A-14 Logic of operation with SAFE alarm locked

- (2) When [P15.01](#) is set to 1, the SAFE alarm function is not locked.

As shown in Figure A-15, no alarm locking refers to that after a SAFE fault occurs and the state is restored, the alarm is automatically deleted. No drive reset is required. The drive executes the running command again after the external running command is reset.

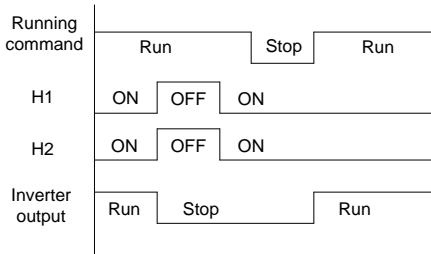

Figure A-15 Logic of operation without SAFE alarm locked

2. STL1 fault

As shown in Figure A-16, when exceptions occur on the hardware line of safety circuit 1 (that is, exceptions occur on the running of H1) but H2 signals are normal, the drive enters the safe operation mode and stops output regardless of the running command. The drive is locked due to the STL1 alarm, and does not execute the running command again even it receives a reset command and the external running command is reset.

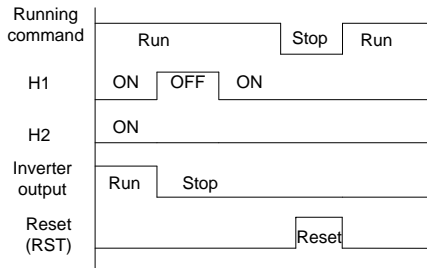

Figure A-16 Logic of operation with safety circuit 1 exceptions

### 3. STL2 fault

As shown in Figure A-17, when exceptions occur on the hardware line of safety circuit 2 (that is, exceptions occur on the running of H2) but H1 signals are normal, the drive enters the safe operation mode and stops output regardless of the running command. The drive is locked due to the STL2 alarm, and does not execute the running command again even it receives a reset command and the external running command is reset.

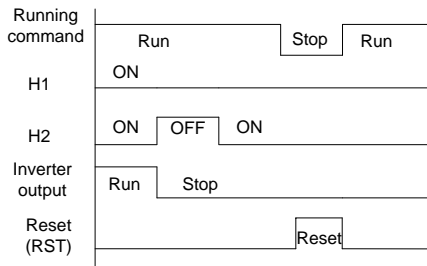

Figure A-17 Logic of operation with safety circuit 2 exceptions

## Appendix B Technical data

### B.1 What this chapter contains

This chapter contains the technical specifications of the inverter, as well as provisions for fulfilling the requirements for CE and other marks.

### B.2 Ratings

#### B.2.1 Capacity

Inverter sizing is based on the rated motor current and power. To achieve the rated motor power given in the table, the rated current of the inverter must be higher than or equal to the rated motor current. Also the rated power of the inverter must be higher than or equal to the rated motor power. The power ratings are the same regardless of the supply voltage within one voltage range.

**Note:**

1. The maximum allowed motor shaft power is limited to 1.5 PN. If the limit is exceeded, motor torque and current are automatically restricted. The function protects the input bridge of the drive against overload.
2. The ratings apply at ambient temperature of 40 °C
3. It is important to check that in Common DC systems the power flowing through the common DC connection does not exceed PN.

#### B.2.2 Derating

The load capacity decreases if the installation site ambient temperature exceeds 40°C, the altitude exceeds 1000 meters or the switching frequency is changed from 4 kHz to 6 or 8 kHz.

##### B.2.2.1 Temperature derating

In the temperature range from +40°C to +50°C, the rated output current is decreased by 3% for every additional 1°C. Refer to the below list for the actual derating.

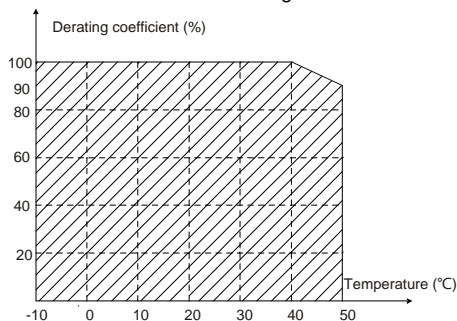

**Note:** It is recommended not to use the inverter at a temperature higher than 50°C. If you do, you need to take all consequences.

##### B.2.2.2 Altitude derating

The device can output rated power if the installation site below 1000m. The output power decreases if

the altitude exceeds 1000 meters. Below is the detailed decreasing range of the derating:

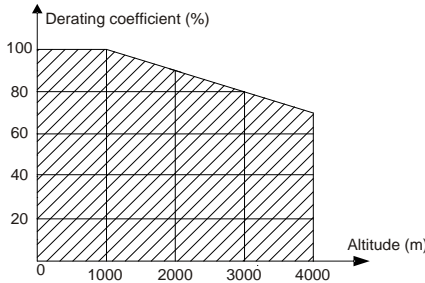

When the altitude exceeds 2000m, configure an isolation transformer on the input end of the inverter. When the altitude exceeds 3000m but is lower than 5000m, contact our company for technical consultation. Do not use the inverter at an altitude higher than 5000m.

**B.2.2.3 Carrier frequency derating**

For GD300L series inverters special for lifts, different power levels correspond to different carrier frequency ranges. The rated power of the inverter is based on the factory carrier frequency, so if it is above the factory value, the inverter needs to derate 20% for every additional 1 kHz carrier frequency.

**B.3 Grid specifications**

Grid voltage	AC 3PH 380V(-15%)–440V(+10%)
Short-circuit capacity	Maximum allowed prospective short-circuit current at the input power connection as defined in IEC 60439-1 is 100 kA. The drive is suitable for use in a circuit capable of delivering not more than 100 kA at the drive maximum rated voltage.
Frequency	50/60 Hz±5%, maximum rate of change 20%/s

**B.4 Motor connection data**

Motor type	Asynchronous induction motor or synchronous permanent magnet motor
Voltage	0 to U1, 3-phase symmetrical, Umax at the field weakening point
Short-circuit protection	The motor output is short-circuit proof by IEC 61800-5-1
Frequency	0...400 Hz
Frequency resolution	0.01 Hz
Current	Refer to Ratings
Power limit	1.5 · PN
Carrier frequency	4, 6, or 8 kHz

### B.4.1 EMC compatibility and motor cable length

To comply with the European EMC Directive (standard 2004/108/EC), use the following maximum motor cable lengths for 4 kHz switching frequency.

All frame sizes (with external EMC filter)	Maximum motor cable length, 4 kHz
Second environment (category C3)	30
First environment (category C2)	30

Maximum motor cable length is determined by the drive's operational factors. Contact the local representative for the exact maximum lengths when using external EMC filters.

For details about environment categories C3 and C2, see "EMC regulations".

## B.5 Applicable standards

The inverter complies with the following standards:

EN/ISO 13849-1:2008	Safety of machinery-safety related parts of control systems - Part 1: general principles for design
IEC/EN 60204-1:2006	Safety of machinery. Electrical equipment of machines. Part 1: General requirements.
IEC/EN 62061:2005	Safety of machinery – Functional safety of safety-related electrical, electronic and programmable electronic control systems
IEC/EN 61800-3:2004	Adjustable speed electrical power drive systems. Part 3: EMC requirements and specific test methods
IEC/EN 61800-5-1:2007	Adjustable speed electrical power drive systems – Part 5-1: Safety requirements – Electrical, thermal and energy
IEC/EN 61800-5-2:2007	Adjustable speed electrical power drive systems – Part 5-2: Safety requirements. Functional.

### B.5.1 CE marking

The CE mark is attached to the inverter to state that the inverter follows the provisions of the European Low Voltage (2006/95/EC) and EMC Directives (2004/108/EC).

### B.5.2 Compliance with the European EMC Directive

The EMC Directive defines the requirements for immunity and emissions of electrical equipment used within the European Union. The EMC product standard (EN 61800-3:2004) covers requirements stated for drives. See section *EMC regulations*.

## B.6 EMC regulations

EMC product standard (EN 61800-3:2004) contains the EMC requirements to the inverter.

First environment: domestic environment (includes establishments connected to a low-voltage

network which supplies buildings used for domestic purposes).

Second environment includes establishments connected to a network not directly supplying domestic premises.

Four categories of the inverter:

Inverter of category C1: inverter of rated voltage less than 1000 V and used in the first environment.

Inverter of category C2: inverter of rated voltage less than 1000 V other than pins, sockets and motion devices and intended to be installed and commissioned only by a professional electrician when used in the first environment.

**Note:** IEC/EN 61800-3 in EMC standard doesn't limit the power distribution of the inverter, but it defines the usage, installation and commission. The professional electrician has necessary skills in installing and/or commissioning power drive systems, including their EMC aspects.

Inverter of category C3: inverter of rated voltage less than 1000 V and used in the second environment other than the first one

Inverter of category C4: inverter of rated voltage more than 1000 V or the nominal current is above or equal to 400A and used in the complicated system in second environment

### B.6.1 Category C2

The emission limits are complied with the following provisions:

1. The optional EMC filter is selected according to the options and installed as specified in the EMC filter manual.
2. The motor and control cables are selected as specified in this manual.
3. The drive is installed according to the instructions given in this manual.
4. For the maximum motor cable length with 4kHz switching frequency, see ***EMC compatibility and motor cable length.***



⚡ In a domestic environment, this product may cause radio inference, in which case supplementary mitigation measures may be required.

### B.6.2 Category C3

The emission limits are complied with the following provisions:

1. The optional EMC filter is selected according to the options and installed as specified in the EMC filter manual.
2. The motor and control cables are selected as specified in this manual.
3. The drive is installed according to the instructions given in this manual.
4. For the maximum motor cable length with 4kHz switching frequency, see ***EMC compatibility and motor cable length.***



⚡ An inverter of category C3 is not intended to be used on a low-voltage public network which supplies domestic premises. Radio frequency interference is expected if the inverter is used on such a network.

## Appendix C Dimension drawings

### C.1 What this chapter contains

Dimension drawings of GD300L series inverters special for lifts are shown below. The dimensions are given in millimeters.

### C.2 Keypad structure

#### C.2.1 Structure chart

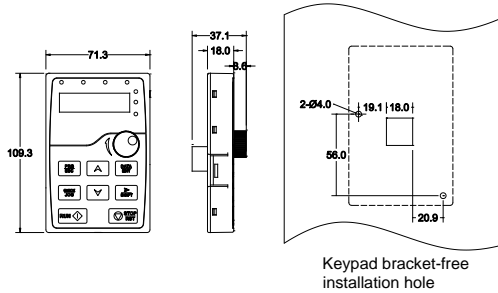

#### C.2.2 Installation bracket (optional)

**Note:** It is necessary to use M3 screw or installation bracket to fix the external keypad. The installation bracket is optional for inverters of 380V 1.5–15kW but it is standard for inverters of 380V 18.5–30kW.

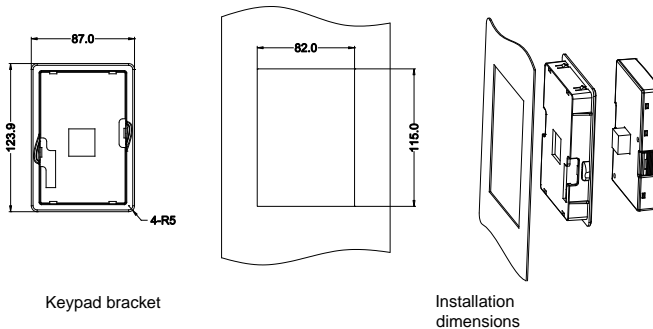

### C.3 Inverter structure

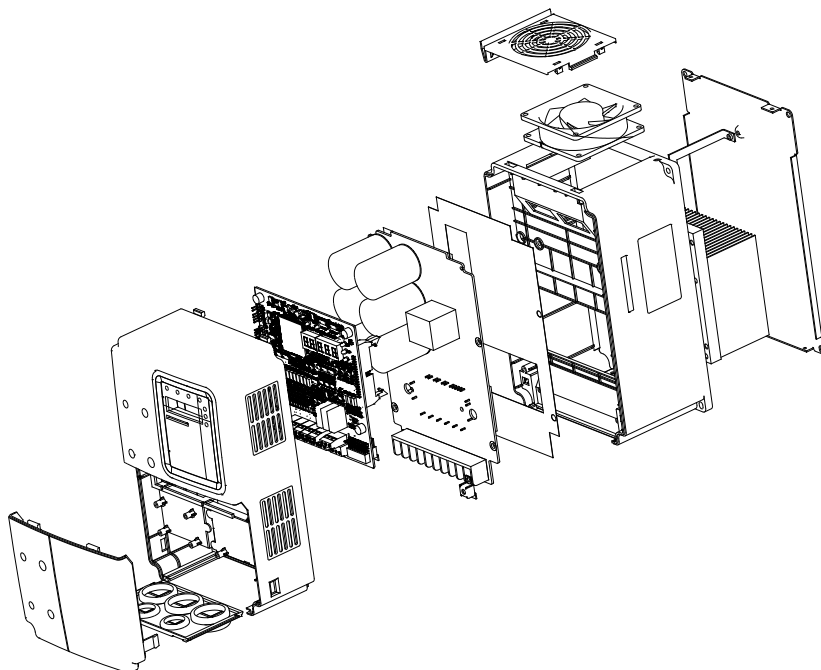

### C.4 Dimensions for inverters of AC 3PH 380V(-15%)–440V(+10%)

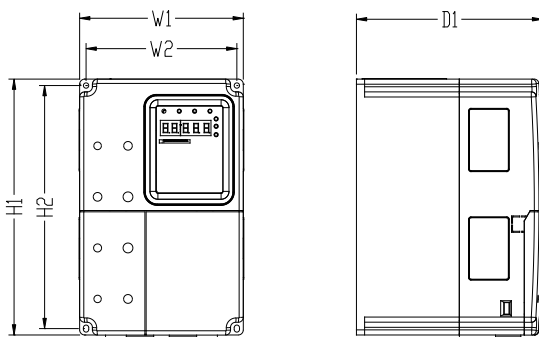

Wall mounting for inverters of 4 kW –15kW

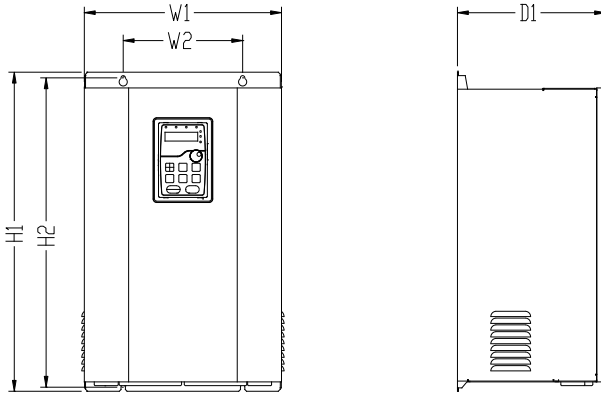

Wall mounting for inverters of 18.5 kW –30kW

Installation dimensions for 380V inverters (unit: mm)

Model	W1	W2	H1	H2	D1	Diameter
4kW–5.5kW	160	147.5	250	237.5	175	5
7.5kW–15kW	220	206	320	305.5	180	6
18.5kW–30kW	290	176	470	455.5	220	6.5

## Appendix D Peripheral optional parts

### D.1 What this chapter contains

This chapter describes how to select the options and parts of GD300L series.





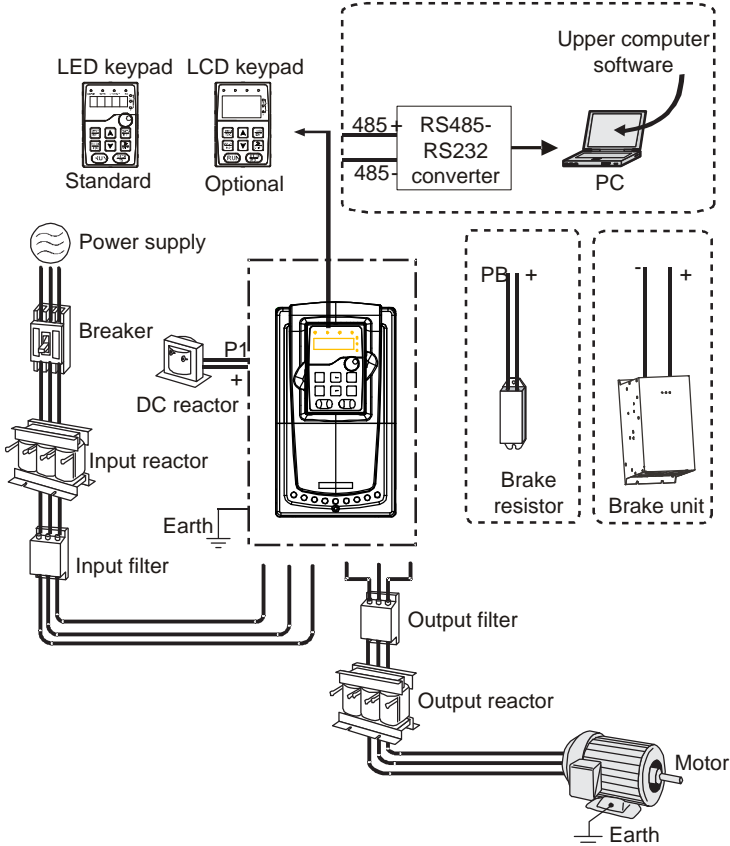

### D.2 Peripheral wiring

Below is the peripheral wiring of GD300L series.

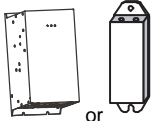

**Note:**

- The inverters of 380V ( $\leq 15\text{kW}$ ) are embedded with brake units. The inverters of 380V ( $\geq 18.5\text{kW}$ ) support optional brake units.
- Brake units are INVT standard brake units. Refer to the instruction of DBU for details.

Picture	Name	Description
	Cables	Device to transfer the electronic signals
	Breaker	Device to prevent the inverter from electric shock and protect the power supply and the cables system from overcurrent when short circuits occur. (Select the breaker with the function of reducing high order harmonic and the rated sensitive current to 1 inverter should be above 30mA).
	Input reactor	Device to improve the power factor of the input side of the inverter and control the higher harmonic current.
	Input filter	Control the electromagnetic interference generated from the inverter, please install close to the input terminal side of the inverter.
	Brake unit or resistor	Shorten the DEC time The inverters $\leq 15\text{kW}$ need brake resistors and the inverters $\geq 18.5\text{kW}$ need brake units.
	Output filter	Control the interference from the output side of the inverter and please install close to the output terminals of the inverter.
	Output reactor	Prolong the effective transmitting distance of the inverter to control the sudden high voltage when switching on/off the IGBT of the inverter.

### D.3 Power supply

Refer to **Electrical installation**.

	⚡ Check that the voltage degree of the inverter complies with the voltage of the supply power voltage.
---	--

### D.4 Cables

#### D.4.1 Power cables

Dimension the input power and motor cables according to local regulations.

- The input power and the motor cables must be able to carry the corresponding load currents.

- The cable must be rated for at least 70 °C maximum permissible temperature of the conductor in continuous use.
- The conductivity of the PE conductor must be equal to that of the phase conductor (same cross-sectional area).
- Refer to chapter **Technical data** for the EMC requirements.

A symmetrical shielded motor cable (see the figure below) must be used to meet the EMC requirements of the CE.

A four-conductor system is allowed for input cabling, but a shielded symmetrical cable is recommended. Compared to a four-conductor system, the use of a symmetrical shielded cable reduces electromagnetic emission of the whole drive system as well as motor bearing currents and wear.

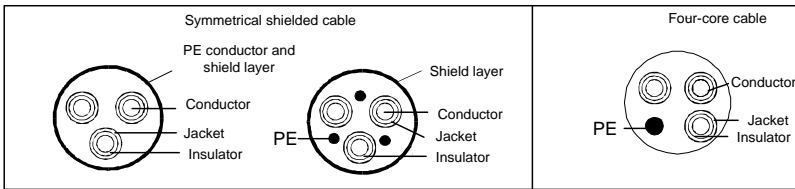

**Note:** A separate PE conductor is required if the conductivity of the cable shield is not sufficient for the purpose.

To function as a protective conductor, the shield must have the same cross-sectional area as the phase conductors when they are made of the same metal.

To effectively suppress radiated and conducted radio-frequency emissions, the shield conductivity must be at least 1/10 of the phase conductor conductivity. The requirements are easily met with a copper or aluminum shield. The minimum requirement of the motor cable shield of the drive is shown below. It consists of a concentric layer of copper wires. The better and tighter the shield, the lower the emission level and bearing currents.

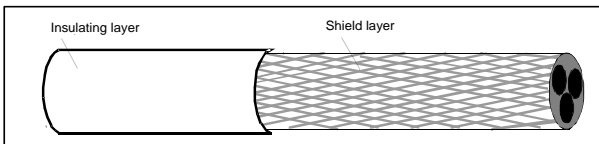

Cross-section of the cable

**D.4.2 Control cables**

All analog control cables and the cable used for the frequency input must be shielded. Use a double-shielded twisted pair cable (Figure a) for analog signals. Employ one individually shielded pair for each signal. Do not use common return for different analog signals.

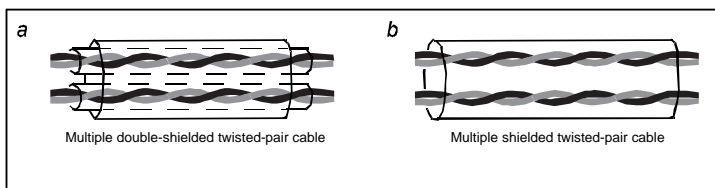

Power cable arrangement

A double-shielded cable is the best alternative for low-voltage digital signals, but a single-shielded or unshielded twisted multipair cable (Figure b) is also usable. However, for frequency input, always use a shielded cable.

**Note:** Run analog and digital signals in separate cables.

The relay cable needs the cable type with braided metallic screen.

The keypad needs to connect with cables. It is recommended to use the screen cable on complex electrical magnetic condition.

Do not make any voltage tolerance or insulation resistance tests (for example hi-pot or megger) on any part of the inverter. Every inverter has been tested for insulation between the main circuit and the chassis at the factory. Also, there are voltage-limiting circuits inside the inverter which cut down the testing voltage automatically.

Check the insulation of the input power cable according to local regulations before connecting to the inverter.

**D.4.2.1 AC 3PH 380V(-15%)–440V(+10%)**

Model	Recommended cable size (mm <sup>2</sup> )		Connecting cable size (mm <sup>2</sup> )				Terminal screw	Tightening torque (Nm)
	RST UVW	PE	RST UVW	P1, (+)	PB (+), (-)	PE		
GD300L-004G-4	2.5	2.5	2.5–6	2.5–6	2.5–6	2.5–6	M4	1.2–1.5
GD300L-5R5G-4	2.5	2.5	2.5–6	4–6	4–6	2.5–6	M4	1.2–1.5
GD300L-7R5G-4	4	4	4–16	4–16	4–16	4–16	M5	2–2.5
GD300L-011G-4	6	6	6–16	6–16	6–16	6–16	M5	2–2.5
GD300L-015G-4	10	10	10–25	10–25	10–25	6–25	M5	2–2.5
GD300L-018G-4	16	16	16–25	16–25	16–25	10–25	M5	2–2.5
GD300L-022G-4	16	16	16–25	16–25	16–25	10–25	M6	4–6
GD300L-030G-4	25	16	16–25	16–25	16–25	16–25	M6	4–6

**Note:**

- It is appropriate to use the recommended cable size under 40°C and rated current. The wiring distance should be no more than 100m..

- Terminals P1, (+), PB and (-) connects the DC reactor options and parts.

#### D.4.3 Routing the cables

Route the motor cable away from other cable routes. Motor cables of several inverters can be run in parallel installed next to each other. It is recommended that the motor cable, input power cable and control cables are installed on separate trays. Avoid long parallel runs of motor cables with other cables to decrease electromagnetic interference caused by the rapid changes in the inverter output voltage.

Where control cables must cross power cables make sure that they are arranged at an angle as near to 90 degrees as possible.

The cable trays must have good electrical bonding to each other and to the grounding electrodes. Aluminum tray systems can be used to improve local equalizing of potential.

A figure of the cable routing is shown below.

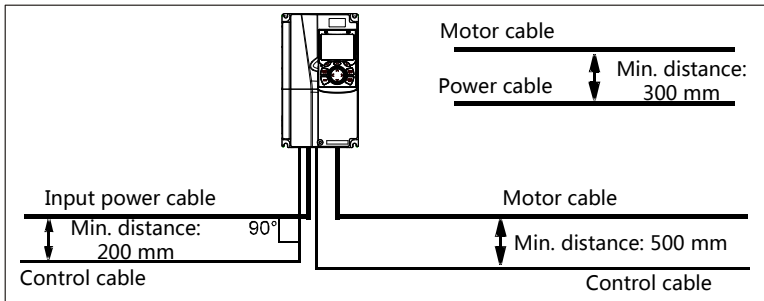

**Cable arrangement distances**

#### D.4.4 Insulation checking

Check the insulation of the motor and motor cable as follows:

1. Check that the motor cable is connected to the motor and disconnected from the inverter output terminals U, V and W.
2. Measure the insulation resistance between each phase conductor and the protective earth conductor using a measuring voltage of 500 V DC. For the insulation resistance of other motors, please consult the manufacturer's instructions.

**Note:** Moisture inside the motor casing will reduce the insulation resistance. If moisture is suspected, dry the motor and repeat the measurement.

#### D.5 Breaker and electromagnetic contactor

It is necessary to add fuse for the avoidance of overload.

It is appropriate to use a breaker (MCCB) between the AC power supply and inverter. The breaker can be locked in the switch-off position. The breaker capacity should be within 1.5-2 times the inverter rated current.



⇨ Due to the inherent operating principle and construction of circuit breakers, independent of the manufacturer, hot ionized gases may escape from the breaker enclosure in case of a short-circuit. To ensure safe use, special attention must be paid to the installation and placement of the breakers. Follow the manufacturer's instructions.

It is necessary to install the electromagnetic contactor in the input side to control the switching on and off safety of the main circuit. It can switch off the input power supply when a system fault occurs.

#### D.5.1 AC 3PH 380V(-15%)–440V(+10%)

Model	Fuse (A)	Breaker (A)	Contactor rated working current (A)
GD300L-004G-4	30	25	16
GD300L-5R5G-4	45	25	16
GD300L-7R5G-4	60	40	25
GD300L-011G-4	78	63	32
GD300L-015G-4	105	63	50
GD300L-018G-4	114	100	63
GD300L-022G-4	138	100	80
GD300L-030G-4	186	125	95

**Note:** The specifications can be adjusted according to the actual working, but they cannot be less than the designated values.

## D.6 Reactors

High current in the input power circuit may cause damage to the rectifying components. It is appropriate to use AC reactor in the input side for the avoidance of high-voltage input of the power supply and improvement of the power factors.

If the distance between the inverter and the motor is longer than 50m, frequent overcurrent protection may occur to the inverter because of high leakage current caused by parasitic capacitance effects from the long cables to the ground. In order to avoid the damage of the motor insulation, it is necessary to add reactor compensation.

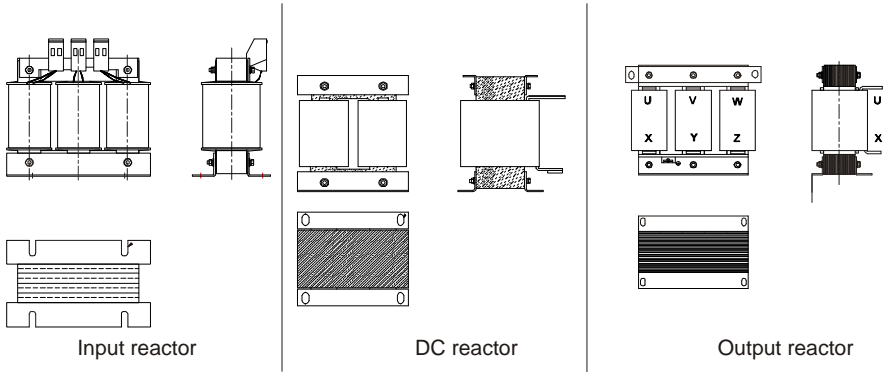

**D.6.1 AC 3PH 380V(-15%)–440V(+10%)**

Model	Input reactor	DC reactor	Output reactor
GD300L-004G-4	ACL2-004-4	/	OCL2-004-4
GD300L-5R5G-4	ACL2-5R5-4	/	OCL2-5R5-4
GD300L-7R5G-4	ACL2-7R5-4	/	OCL2-7R5-4
GD300L-011G-4	ACL2-011-4	/	OCL2-011-4
GD300L-015G-4	ACL2-015-4	/	OCL2-015-4
GD300L-018G-4	ACL2-018-4	Embedded	OCL2-018-4
GD300L-022G-4	ACL2-022-4		OCL2-022-4
GD300L-030G-4	ACL2-037-4		OCL2-037-4

**Note:**

- The rated derate voltage of the input reactor is 2%±15%.
- The power factor of the input side is above 90% after installing DC reactor.
- The rated derate voltage of the output reactor is 1%±15%.
- Above options are external, the customer should indicate when purchasing.

**D.7 Filter**

The input interference filter can decrease the interference of the inverter to the surrounding equipment.

The output interference filter can decrease the radio noise cause by the cables between the inverter and the motor and the leakage current of the conducting wires.

Our company configured some filters for the convenient of the users.

## D.7.1 Filter type designation key

**FLT-P 04 045 L-B**

A      B      C      D      E      F

Key	Description
A	FLT: inverter filter series
B	Filter type P: power supply filter L: output filter
C	Voltage degree 04: AC 3PH 380V(-15%)–440V(+10%)
D	3 bit rated current code. "015" means 15A.
E	Filter performance L: Common H: High performance
F	Filter utilization environment A: First environment (IEC61800-3:2004)category C1 (EN 61800-3:2004) B: First environment (IEC61800-3:2004)category C2 (EN 61800-3:2004) C: Second environment (IEC61800-3:2004)category C3 (EN 61800-3:2004)

## D.7.2 AC 3PH 380V(-15%)–440V(+10%)

Model	Input filter	Output filter
GD300L-004G-4	FLT-P04016L-B	FLT-L04016L-B
GD300L-5R5G-4		
GD300L-7R5G-4	FLT-P04032L-B	FLT-L04032L-B
GD300L-011G-4		
GD300L-015G-4	FLT-P04045L-B	FLT-L04045L-B
GD300L-018G-4		
GD300L-022G-4	FLT-P04065L-B	FLT-L04065L-B
GD300L-030G-4		



**Note:**

1. The input EMI meet the requirement of C2 after installing input filters.
2. Above options are external, the customer should indicate when purchasing.

## D.8 Braking system

### D.8.1 Selecting the braking components

It is appropriate to use brake resistor or brake unit when the motor brakes sharply or the motor is driven by a high inertia load. The motor will become a generator if its actual rotating speed is higher than the corresponding speed of the reference frequency. As a result, the inertial energy of the motor and load return to the inverter to charge the capacitors in the main DC circuit. When the voltage increases to the limit, damage may occur to the inverter. It is necessary to apply brake unit/resistor to avoid this accident happens.

	<ul style="list-style-type: none"> <li>✧ Only qualified electricians are allowed to design, install, commission and operate on the inverter.</li> <li>✧ Follow the instructions in "warning" during working. Physical injury or death or serious property may occur.</li> <li>✧ Only qualified electricians are allowed to wire. Damage to the inverter or braking options and part may occur.</li> <li>✧ Read carefully the instructions of brake resistors or units before connecting them with the inverter.</li> <li>✧ Do not connect the brake resistor with other terminals except for PB and (-). Do not connect the brake unit with other terminals except for (+) and (-). Damage to the inverter or braking circuit or fire may occur.</li> </ul>
	<ul style="list-style-type: none"> <li>✧ Connect the brake resistor or brake unit with the inverter according to the diagram. Incorrect wiring may cause damage to the inverter or other devices.</li> </ul>

### D.8.2 AC 3PH 380V(-15%)–440V(+10%)



The inverters ≤15kW have embedded brake units but the 18.5–30kW inverters support optional brake units. Please select the brake resistor according to actual operation.

Model	Brake unit	Braking resistance at 100% of braking torque (Ω)	Brake resistor consumption power (kW)			Min. braking resistance (Ω)	Recommended braking resistance	Recommended resistor power
			10% braking usage	50% braking usage	80% braking usage			
GD300L-004G-4	Embedded	122	0.6	3	4.8	80	122Ω	1200W
GD300L-5R5G-4		89	0.75	4.1	6.6	60	65Ω	1600W
GD300L-7R5G-4		65	1.1	5.6	9	47	50Ω	1600W
GD300L-011G-4		44	1.7	8.3	13.2	31	40Ω	4800W
GD300L-015G-4		32	2	11	18	23	32Ω	4800W
GD300L-018G-4		27	3	14	22	19	28Ω	6000W
GD300L-022G-4	DBU-055-4	22	3	17	26	17	20Ω	9600W
GD300L-030G-4		17	5	23	36	17	16Ω	9600W

**Note:**

- Select the resistor resistance and power of brake units based on the data provided by INVT.

- Brake resistors may increase the braking torque of the inverter. The resistor power values in the above table are designed based on 100% of braking torque, and 10%, 50%, and 80% braking use ratios. Select a braking system depending on the actual working condition.
- If you need to use external brake units, see the instructions on dynamic brake units to set the braking voltage degrees of brake units. Incorrect voltage degrees may affect the normal running of the inverter.

	⇨ Never use a brake resistor with a resistance below the minimum value specified for the particular drive. The drive and the internal chopper are not able to handle the overcurrent caused by the low resistance.
	⇨ Increase the brake resistor power according to the above table in frequent braking situations (where braking usage > 10%).

**D.8.3 Selecting brake resistor cables**

Use shielded cables to serve as brake resistor cables.

**D.8.4 Installing brake resistors**

Install all resistors in the place with sufficient ventilation.

	⇨ The materials near brake resistors must be non-flammable. The surface temperature of resistors is high. Air flowing from the resistors is of hundreds of degrees Celsius. Protect the resistor against contact.
---	---

Brake resistor installation

	⇨ The inverters of 380V ( $\leq 15kW$ ) only need external brake resistors. ⇨ PB and (+) are the wiring terminals of the brake resistors.
---	--

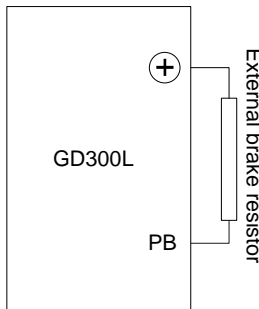

Brake unit installation

	⇨ Inverters of 380V 18.5–30kW support external brake units. ⇨ (+) and (-) are the connection terminals of brake units. ⇨ Both the wiring length between the inverter terminal (+) and brake unit terminal (+) and length between the inverter terminal (-) and brake unit
---	---

terminal (-) must be no more than 5 meters. Both the length of the cable connecting BR1 to one brake resistor terminal and length of the cable connecting BR2 to the other brake resistor terminal must be no more than 10 meters.

Signal-inverter connection

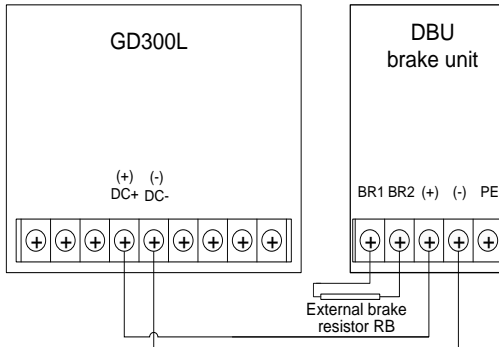

### D.9 Emergency operation systems

The table below lists emergency operation systems, which can be purchased as required.

No.	Name	Model	Function
1	Storage battery protection board	ASY01_PA1602_CV1	Installs diodes D1 and D2 to protect the storage battery.
2	Control power board	ASY01_PA0001_PW1	Boosts the UPS power to power the control board in emergency operation.
3	Connection cable	1 meter	Connects the drive board to the control power board.

## Appendix E Further information

### E.1.1 Product and service inquiries

Should you have any queries about the product, contact the local INVT office. Provide the model and serial number of the product you query about. You can visit [www.invt.com.cn](http://www.invt.com.cn) to find a list of INVT offices.

### E.1.2 Feedback on INVT Inverters manuals

Your comments on our manuals are welcome. Visit [www.invt.com.cn](http://www.invt.com.cn), and directly contact online service personnel or choose **Contact Us** to obtain contact information.

### E.1.3 Documents on the Internet

You can find manuals and other product documents in the PDF format on the Internet. Visit [www.invt.com.cn](http://www.invt.com.cn) and choose **Service and Support > Data Download**.



The products are owned by **Shenzhen INVT Electric Co.,Ltd.**

Two companies are commissioned to manufacture: (For product code, refer to the 2nd/3rd place of S/N on the name plate.)

**Shenzhen INVT Electric Co., Ltd.** (origin code: 01)

Address: INVT Guangming Technology Building, Songbai Road,  
Matian, Guangming District, Shenzhen, China

**INVT Power Electronics (Suzhou) Co., Ltd.** (origin code: 06)

Address: 1# Kunlun Mountain Road, Science&Technology Town,  
Gaoxin District, Suzhou, Jiangsu, China

**Industrial Automation:** ■ Inverter

■ Servo & Motion Control

■ Motor & Electric Spindle

■ PLC

■ HMI

■ Intelligent Elevator Control System

■ Traction Drive

**Electric Power:**

■ SVG

■ Solar Inverter

■ UPS

■ Online Energy Management System



6 6 0 0 1 - 0 0 4 5 0

Copyright© INVT.

Manual information may be subject to change without prior notice.

201904 (V1.2)